

G-Series User Manual

Positive Displacement Gear Flow Meters



G004

G015

G045

G105

G240

G004HZ

G015HZ

G045HZ

max
Precision Flow Meters

Safety and Precautions



For flow meters approved for use in a hazardous environment, refer to the EXInstallSheet for installation instructions. Failure to follow the EXInstallSheet instructions shipped with the product may result in death or serious injury. For flow meters rated for ATEX, UL, or cUL Class 1, Div. 1 use in a hazardous environment, contact Max Machinery Sales at 707.433.2662 or www.maxmachinery.com.



Never run the meter dry or blow compressed air through the meter. Damage will occur.



Never steam clean the meter. Damage will occur. (Bypass or remove the meter if necessary).



Do not run water or aqueous solutions not approved by Max through your flow meter. Damage will occur.



Do not disassemble the meter. Damage may occur. No serviceable parts inside.



Do not over pressurize the meter. Damage may occur.



Do not remove the transmitter from the flow meter body unless advised by Max. Re-phasing the transmitter to the flow meter body via the Interface Software Kit is required to prevent measurement error. (isnt this what the gold comepnasation button is for?)



Do not apply excessive differential pressure across the flow meter. Damage will occur. See pressure drop curves for safe area operation.



Do not exceed maximum flow rate for the material viscosity. Damage will occur.



Do not allow materials to cure in the flow meter. If materials cannot be flushed from the meter, damage may occur.



Do not flow remeltable materials through the meter until fully liquefied. Solids may damage the meter.



Read the entire manual before installing and operating the meter.



Verify the fluid to be measured is compatible with the flow meter.



Filter your fluid to prevent damage from debris and foreign materials.



Install bypass plumbing around the flowmeter to allow for easier servicing and line purging/flushing without damaging the meter.



Follow all local regulations and your company safety procedures when installing, operating, servicing, and maintaining your flow meter.

Table of Contents

Safety and Precautions	i
Table of Contents	ii
How It Works	1
Installation Mechanical	2
Mechanical Operation	4
Installation Electrical	5
Electrical Quick Start	6
Field Compensation of Transmitter	10
LED Functions	12
Specifications	13
Dimensions	19
Optional Heater Block	30
Charts	31
Part Matrix	33
Available Accessories	35
Troubleshooting and Service Request	36
Additional Information Available	36

Max Machinery, Inc. (MMI) reserves the right to change product specifications without notice to improve performance, reliability, or manufacturability. MMI shall not be held liable for operational, technical, or editorial errors/omissions. Visit our web site for the latest version of this user manual.

Max Machinery, Inc., 33A Healdsburg Avenue, Healdsburg, CA 95448 USA
707.433.2662 | www.maxmachinery.com

max
Precision Flow Meters

How It Works

Max G-Series Precision Flow Meters are positive displacement gear meters that are able to operate over a wide range of flow rates and fluid viscosities. High accuracy measurement is achieved through precision machined spur gears that move proportional to the flow. High resolution outputs are produced by measuring the rotation of the gears and converting the signals to analog or frequency outputs. Flows can be monitored from 0.5 cc/min up to 240 liters/min with fluid temperatures from -40°C to 225°C and pressure ratings of 6000 psi (414 bar) depending upon model. The industrial meter electronics are protected against water, dust, and most corrosive liquids. The 5-pin Turck connector provided is IP68. Additionally, IP66 rated explosion proof enclosures, combined with a choice of one-part and two-part, high temperature designs with remote electronics cover a wide range of application environments - from the laboratory to harsh industrial processes. Optional seal materials allow for different fluid compatibility.

Max Machinery, Inc. designs, manufactures, calibrates, and refurbishes high accuracy, high resolution, precision liquid flow meters under an ISO 9001:2015 certified quality management system. All Max Precision Flow Meters are tested and calibrated in our lab and provide measurements traceable to NIST. If your calibration certificate is lost or missing, contact MMI with your meter serial number for a copy.

Installation - Mechanical

Your Max Flow Meter has been configured at the factory to be used out of the box based on your submitted application data. Plumb it, wire it, and use it. The following section will provide instructions on how to properly plumb your Max Flow Meter in the liquid lines of your application.

Use the "IN" port or follow the flow direction arrow markings for the primary flow direction. Install the meter on the discharge side of the pump whenever possible. Excessive vibration at the meter should be avoided.

Orientation: Preferred mounting orientation of the meter depends on meter type. The orientation optimizes air purging and/or minimizes heat transfer to the electronics. G-Series meters, especially when used with thick fluids, should mount with the transmitter on the side and the plumbing oriented vertical flow up. This mounting orientation prevents air in the system that can cause response delays and errors in measurement.

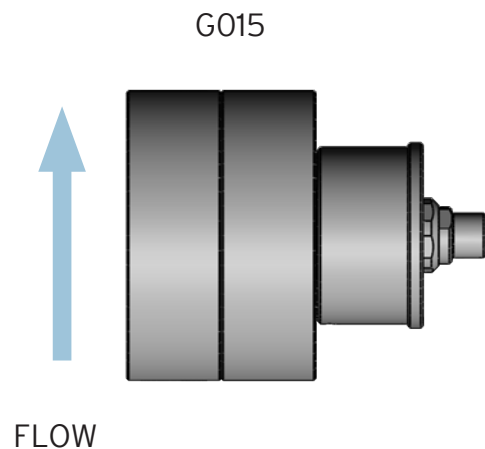

NPT fittings: Always use pipe sealant or pipe tape to install fittings, and leave the first thread of pipe exposed. Ensure the tape or sealant does not accidentally enter the meter.

SAE fittings: Always use process fluid compatible lubricant on the o-ring to attach the fitting to the meter.

Installation - Mechanical

Bypass Valves: Install valves to allow system start-up, filter replacement, or flow meter removal without completely shutting down the system and draining the lines. See diagram.

Failure to use a bypass at start up may lead to flow meter damage due to debris, overspeeding the meter with air in the lines, and pressure shock due to initial line surges.

Filtration: A 10 micron filter is recommended on the inlet side of the meter for G004 and G015 flow meters. A 30 micron filter is recommended for G045, G105, and G240 flow meters. If measuring bi-directional flow, a filter should be installed on both sides of the flow meter. Materials with fibrous or non-abrasive particulate matter may need to be run without filters.

Clean Plumbing: Before installing the flow meter, the system lines shall be cleaned and free of all debris or manufacturing particulates. Purging lines with compressed air or steam are typical cleaning methods. Do not use compressed air or steam on the Max flow meter, damage will occur.

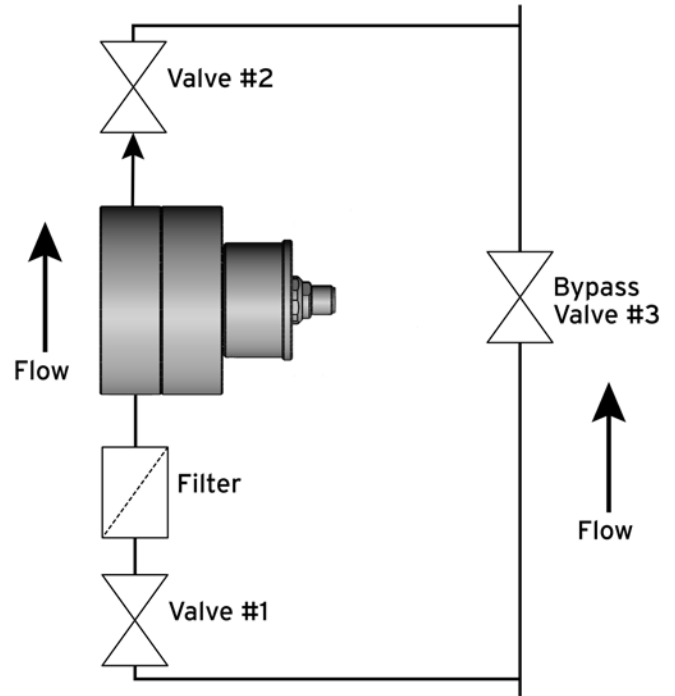

High Temperatures: Orient your meter so the transmitter is to the side or below to minimize heat transfer by convection from the flow meter to the transmitter. The transmitter is the most heat sensitive element in the system. Consult [page 8](#) for specific limits on fluid and ambient maximum temperatures. When operating in the upper temperature ranges, always insulate the meter but leave the transmitter housing exposed so it radiates heat. An optional heater block can be used on the flow meter to keep it at the fluid operating temperature. For substances solid at room temperature, a heater block may be required to keep material molten to flow through the meter.

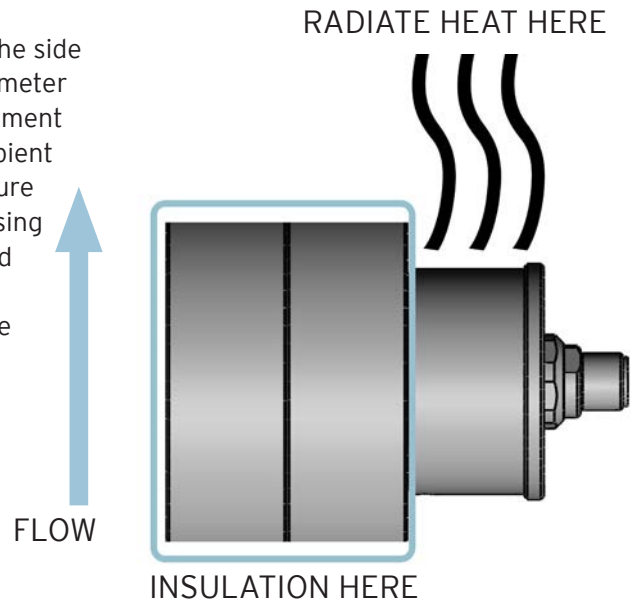

Mechanical - Operation

Determine that the following parameters of your flow metering system are within the specifications for the specific meter being used:

- Maximum System Pressure (Specifications)
- Differential Pressure across meter (Pressure Drop Curves)
- Maximum Flow Rate (Pressure Drop Curves)
- Metered Fluid Temperature (Sales specification, transmitter specifications page 8)

If the metered fluid is greater than 28°C (80°F) over ambient, see the “High Temperature Start Up” section below.

With valves (#1) and (#2) closed, slowly open valve (#3) (bypass) to clear the lines of foreign particles and air. Slowly open the inlet valve (#1). Slowly open the outlet valve (#2). Completely close the bypass valve.

No routine maintenance, cleaning, or lubrication of the flow meter is required. A routine filter cleaning schedule should be established. The system should be shut down if abnormal noises occur or if unusual differential pressures across the meter are encountered.

High Temperature Start Up: For fluids above 82°C (150°F) based on 21°C (70°F) ambient, a special procedure is required to prevent thermal shock and permanent damage to the flow meter. The warm up time is determined by the equation below:

$$\text{TIME (minutes)} = \frac{\text{connector size (inches)} \times (\text{operating temperature (°F)} - 125)}{10}$$

– OR –

$$\text{TIME (minutes)} = \frac{\text{connector size (inches)} \times (\text{operating temperature (°C)} - 52)}{10}$$

Valves (#1) and (#2) must be closed. Open the bypass valve (#3) in gradual steps until the bypass piping is stabilized at operating temperature. Open valve (#1) slightly and allow the temperature to stabilize around the flow meter. Valve (#1) can then be opened completely.

Open valve (#2) slightly. The flow meter may make unusual noises or bind at this point. Leave the valve at this setting until normal meter operation occurs, at which point valve (#2) can be gradually opened all the way. Slowly close the bypass valve (#3).

Installation - Electrical



WARNING: Electrical shock hazard. Serious or fatal injury may occur. Installation/Removal should only be completed by trained and authorized personnel.



WARNING: Refer to the EXInstall Sheet for proper installation in hazardous locations.



CAUTION: Verify transmitter output type (Analog or Frequency) before wiring. Inappropriate wiring could result in damaging the circuit.



CAUTION: Before opening/accessing the electronics lid, make sure the top of the meter and surrounding components are dry and no moisture or fluids can contact the electrical components. Non-warranty damage may occur.

Max G-Series Precision Flow Meters transmitters come from the factory pre-assembled to the mechanical metering component and configured to be used out of the box based on your submitted application data. Plumb it, wire it, and use it. The following section will describe how to properly wire your Max Flow Meter into the electronics of your application.

There are various combinations of transmitter components and outputs. These options include:

- Industrial or Hazardous Location Transmitter Housing
- Frequency or Analog Output Signal
- Uni-directional or Bi-directional Output Signal
- Standard, High Temperature, and Ultra High Temperature Housings

To determine what transmitter type you have, refer to the Max part number matrix on [pages 33-34](#) and decode your flow meter's part number.



Installation - Electrical

Quick Start - No adjustments to factory settings

Your Max Flow Meter is connected to your process automation electronics via a 5-pin M12 Turck connector if an Industrial Transmitter or via a 5-pin connector within a Hazardous Location housing with a 1/2 inch conduit connection. Please refer to the EXInstall Sheet for proper installation of the wiring to the Hazardous Location housing.

Wire the 5-pin Turck cable to your process automation equipment in accordance with the diagrams below depending upon which transmitter type you purchased. Then connect the Turck cable to the Turck fitting on the Max Flow Meter.

Set your output reading on your process automation electronics to match the calibration sheet supplied with your flow meter.

You are ready to measure your liquid flow application.

Start-up Instructions - Adjustments to Factory Settings Required

If you need to make adjustments to your Max Flow Meter prior to use, you will need to purchase and use the Max Machinery Interface Software Kit. This will allow you to change the flow meter output signal frequency or analog range to meet your application's equipment needs.

To access the port on the circuit board, unscrew the transmitter lid by hand. The transmitter lid has four thread paths. When reinstalling the lid, the cable may be misaligned. To realign the cable, remove the lid and rotate up to 180° and retighten using an alternate starting point. Tighten to compress the O-ring seal.

Max Flow Meters do not come with a visual interface, they must be connected to an electronic display, PLC/DAC/counter card or other process automation electronics to collect the data and display a visual reading.

You must determine if your process automation electronics have the capability to accept the high frequency output of the Max Flow Meter. If your system cannot accept the data at the pre-set frequency, then use the Max Machinery Interface Software Kit to adjust the frequency output to a lower setting that matches your system.

Refer to the Max Machinery Interface Software Kit Manual for instructions on how to change the flow meter output signal frequency or analog range to meet your application's equipment needs.

Electrical Installation Instructions - 5-pin Turck Connectors

Applies only to transmitters with 5-pin, M12 style connectors. For hazardous location transmitters with 1/2 inch conduit connections, please refer to the EXInstall sheet.

Frequency Output Transmitters (PN ending N/-)

	Turck® Connector		
	PCA Label	Pin #	Mating Cable Wire Color
Power (+5 to 26 Vdc)	V+	1	Brown
Common	Com	4	Black
Pulse Output	Ph A	2	White
Output Phase B (Quad only)	Ph B	5	Grey
Case Ground	Case	3	Blue



Current Sinking Wiring (PN ending S/-)

A current sinking device uses the transmitter's transistor output to act as a switch. Positive DC voltage must be applied to the transmitter's output pin (#2). When the pulse output is triggered, this voltage is grounded to zero volts by the transmitter. Warning: Use a 5k ohm resistor to limit current if your system does not have other means to limit current into the transmitter.

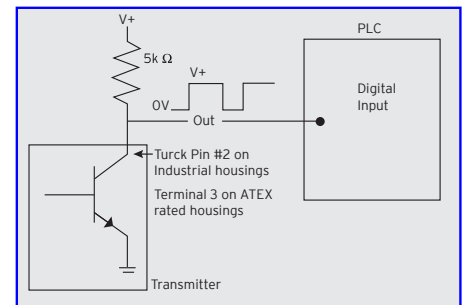

Analog Current or Voltage Output Transmitters (PN ending A/-, B/-, C/-, or D/-)

	Turck® Connector		
	PCA Label	Pin #	Mating Cable Wire Color
Power *	V+	1	Brown
Common	Com	4	Black
Signal Output (+)	Sig	5	Grey
Signal Output (-)**	Ret	2	White
Case Ground	Case	3	Blue



* Analog transmitters with part numbers ending in A/- or C/- are 24Vdc power. Part numbers ending in B/- or D/- are 12Vdc power.

** To minimize signal noise, analog output transmitters are fully isolated. If your PLC does not ground the negative signal input, there is a risk of a ground shift that could drive the signal out of the range of detection. To prevent this from occurring, install a 10k pull down resistor between Common and Signal Output (-).

Electrical - Operating Information

Max Flow Meters require a fully isolated power supply to operate. Refer to the Max Machinery Interface Software Kit Manual for instructions on how to change the flow meter output signal frequency or analog range to meet your application's equipment needs.

Transmitters should not be removed from the flow meter for any field servicing or adjustments. The flow meter and transmitter must be shipped back to the factory for calibration or service as the complete serialized unit.

Removal note: If an industrial transmitter needs to be removed from the flow meter for installation, be sure to retighten the transmitter snugly in order to ensure proper sensor alignment. To remove, disconnect the Turck cable and unscrew the industrial transmitter. Use a wrench if necessary. To reattach the industrial transmitter, hand tighten only (~3 ft-lb). For Hazardous Location transmitters, refer to the EXInstall Sheet for proper installation.

Moisture Seal Protection: On all models, the housing is designed as a liquid and vapor-tight enclosure. There are O-ring seals at the lid and also the base of the housing in some models; these need to be fully seated. A properly sealed transmitter will prevent the formation of damaging moisture inside the housing. Industrial transmitters have Turck connectors sealed to the lid at the factory and are ready for use. There are no adjustments or servicing that require the connector to be removed from the transmitter lid. Hazardous Location transmitters have an NPT connection. Refer to the EXInstall Sheet for proper installation.

Environmental: The Industrial transmitters are rated to operate in the following fluid temperature ranges at ambient temperature ranges of -40°C to 80°C Standard and 110°C High and Ultra High Temperature Housings. With ambient temperature increases, the maximum fluid temperature at the flow meter is de-rated as shown in the charts below. Hazardous location transmitters have different ambient and fluid temperature ratings, refer to the EXInstall Sheet for proper installation.

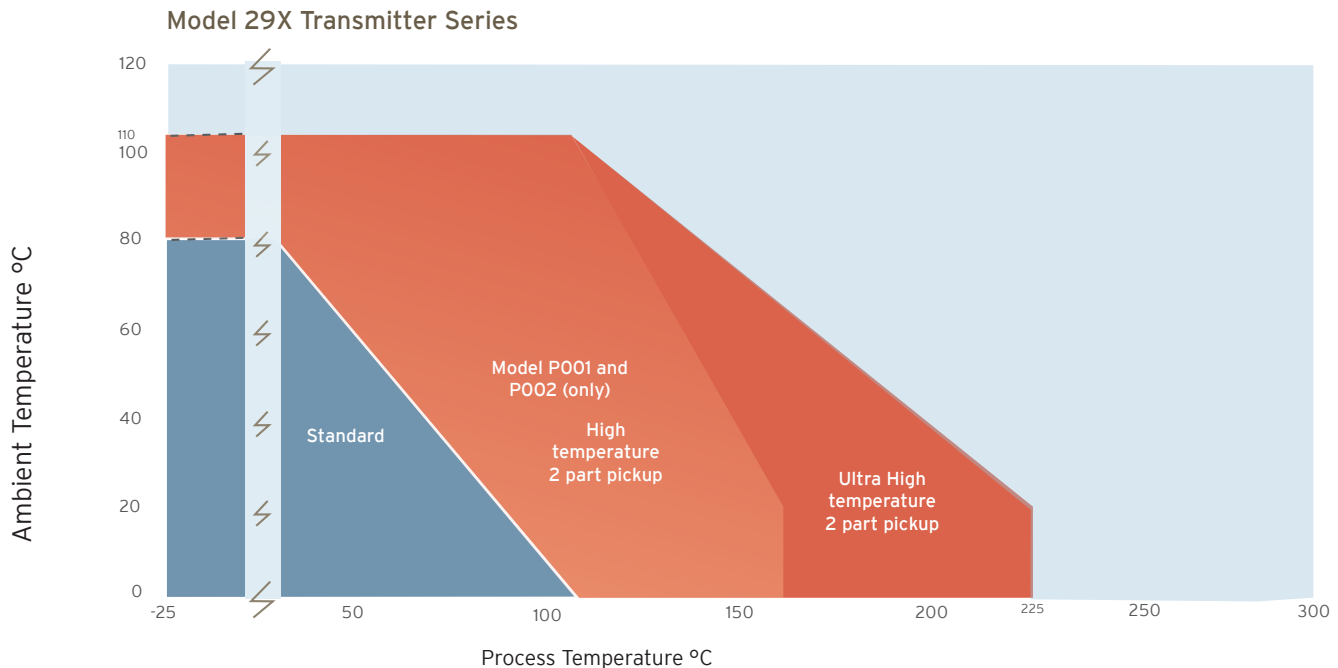

High Temperature Instructions

Orient your meter so the transmitter is to the side or below to minimize heat transfer by convection from the flow meter to the transmitter. The transmitter is the most heat sensitive element in the system. Consult the table on [page 8](#) for specific limits on fluid and ambient maximum temperatures. When operating in the upper temperature ranges, always insulate the meter but leave the transmitter housing exposed so it radiates heat. An optional heater block can be used on the flow meter to keep it at the fluid operating temperature. For substances solid at room temperature, a heater block may be required to keep material molten to flow through the meter.

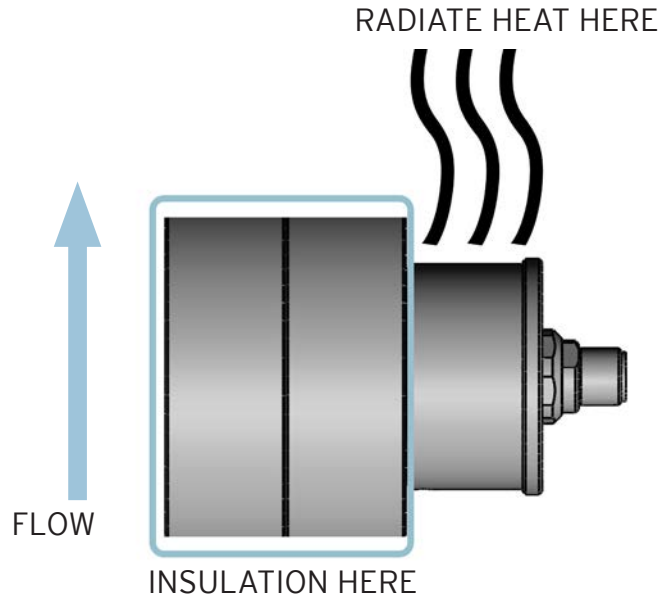

Troubleshooting

LED Rotation/Output Indicators

All Max transmitters incorporate an alternating red/green or blue/green LED to indicate magnet rotation in the meter. The color changes each 1/2 revolution of the meter. Additionally, when no flow signal is present, a rapidly flashing red light indicates the following errors:

Frequency (PN ending N/- or S/-):

Flashes 8x per second indicate magnet is not detected

Analog (PN ending A/-, B/-, C/-, D/-):

Flashes 2x per second indicate excessive temperature

Flashes 8x per second indicate magnet is not detected

Flashes 16x per second indicate a wiring fault in the output circuit

Note: There are no selections or adjustments on the circuit board. Setting changes are made through the Interface Software Kit (SFT-KIT-001), sold separately.

Field Compensation of Transmitter

The transmitter LED on the circuit board indicates a functioning system when it is producing a pulse output or detecting magnet travel in the meter.

An alternating blue/green LED indicates that the circuit is detecting a magnet and provides an output signal.

A steady or flashing red LED indicates a problem with the transmitter PCA. Contact Max Machinery to have your flow meter refurbished.

The Compensation Algorithm adjusts for variations in Hall sensor and flow meter characteristics to provide a stable, undamped output frequency that accurately represents the instantaneous flow rate. This feature is factory set when the meter is assembled. If the transmitter PCA is replaced or reset, the compensation can be performed via the gold PCA button or through the software kit.

The only method of altering additional factory set parameters of the meter is through the Interface Software Kit, part number SFT-KIT-001. Pulse Output Scaling, Analog Output Limits and Scaling, Signal Filtering Options and Compensation settings are the adjustable variables.



WARNING: Electrical shock hazard. Serious or fatal injury may occur. Access should only be completed by trained and authorized personnel.



CAUTION: Before opening/accessing the electronics lid, make sure the top of the P234 meter and surrounding components are dry and no moisture or fluids can contact the electrical components. Non-warranty damage may occur.

Instructions to access the gold PCA button and software serial port:

- Unscrew the captured philips head screws on the electronics lid.
- Remove and set aside the lid with o-ring seal.
- Optional: follow instructions for SFT-KIT-001 to connect to software serial port.
- Follow field compensation instructions on [page 11](#).
- To reinstall, ensure the o-ring seal is firmly seated. Assembly is then the reverse of disassembly.

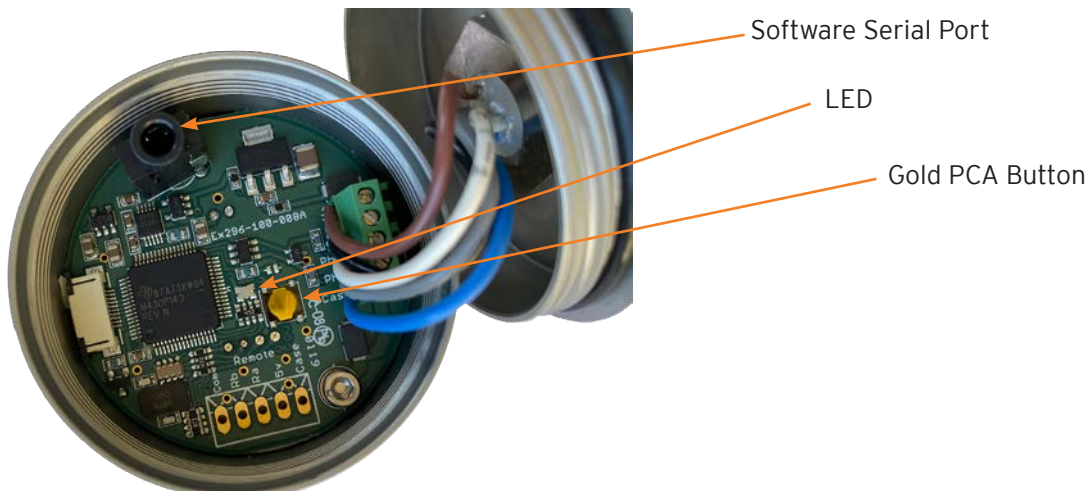

Field Compensation of Transmitter Continued

When a transmitter PCA is replaced or reset in the field, the compensation routine should be performed to optimize the performance of the system. This routine requires a steady flow rate for the flow meter model as shown in Table A below. The flow meter being compensated must not be used for system flow rate feedback control during this process. The transmitter output is disabled during the compensation routine.

If you are unable to run a stable flow in the field, send your meter in to Max Machinery for calibration.

The compensation routine is as follows:

1. Place your system in 'manual' mode or run in 'open loop' mode with no flow meter feedback control. Max transmitter output shuts off during field compensation routine. Loss of signal to 'closed loop control' modes can affect the flow stabilization of the system and the compensation of the Max meter.
2. Stabilize the flow rate for your flow meter model as shown in Table A below.
3. Activate the compensation routine:
 - A - When using the software via the serial port connection, select 'field compensation' in the software.
 - OR
 - B - If NOT using software, push the Gold PCA Button using a non-conductive tool.
4. The blue/green LED will change to solid blue for 5 revolutions of the meter. See table LED Functions on next page for duration of compensation process. Duration is dependent upon flow rate and requires at least 10 seconds at maximum flow and 90 seconds at minimum flow.
5. A green LED light indicates a successful update of the compensation, a red LED light indicates the new compensation failed. Additional information is available through the interface software.
6. Return your system to 'operating' mode or restore settings to allow for feedback control.

Field Compensation Flow Rate Table A

Max Flow Meter	Minimum Flow Rate (cc/min)	Maximum Flow Rate (cc/min)
G004	7	2210
G015	16	5155
G045	52	16,570
G105	146	46,640
G240	512	163,270

LED Functions

Normal Operation		
STATUS	LED	ACTION
Functioning - System Not Flowing	Blue or Green Steady	Meter is functioning, but no flow is detected in the system.
Functioning - System Flowing	Blue / Green alternating colors	Meter is functioning, flow is occurring in the system. Note: At high flow rates the alternating Blue/Green flashes may appear as a single steady color.
Meter Malfunction	Red Steady	Refurbish Meter.
No Power / Meter Failure	No Light	<ul style="list-style-type: none"> - Verify power supply to meter. - Verify wiring follows diagrams on page 4. - If power and wiring are verified, refurbish meter.

Compensation via Interface Software Kit or Gold PCA Button		
STATUS	LED	ACTION
Compensate button pushed/clicked	Blue Steady	- Steady light for 4-5 revolutions of meter.
Compensation Succeeded	Green Steady	<ul style="list-style-type: none"> - Steady light for 5 seconds. - Software will show "Success" on screen.
Compensation Failed	Red Steady	<ul style="list-style-type: none"> - Steady light for 5 seconds. - Software will show "Flow too low/ too high/ unstable" on screen.
<p>Note: Revolutions of meter are dependent on expected fluid flow rate. Per Table A, the maximum compensation flow rate will take approximately 10 seconds and the minimum compensation flow rate will take approximately 90 seconds to complete 5 revolutions at the stated flow rates.</p>		
<p>If compensation fails, restart the compensation process. When using the Interface Software Kit, follow instructions provided to correct errors prior to attempting compensation again. If problems persist, contact Max Machinery at 707-433-2662 or at www.maxmachinery.com.</p>		

Specifications

G004 SPECIFICATIONS

Flow Range	0.5 cc/min to 4 liters/min
Accuracy (at 30 cP)	± 0.3% of reading over a 100:1 range
Maximum Operating Pressure	6000 psi (414 bar)
Weight	1.1 kg
Recommended Filtration	10 micron
Port Size(s)	1/8" NPT or #4 SAE or Manifold Mount
Fluids	Most non-aqueous, hydrocarbon based fluids

MATERIALS OF CONSTRUCTION

External	Stainless Steel, type 303, Fluoropolymer coated bolts; MoS2 lubricant
Wetted	Stainless Steel, type 303, 440C, 17-4
O-Rings	Standard: Viton® Optional: Teflon®, Perfluoroelastomer

FREQUENCY TRANSMITTER

Output Signal	Standard: 5 Vdc, single phase Optional: Quadrature 5 Vdc, two phase Current sinking, 20 mA max., single phase
K-Factor	Single Phase: 500 pulses/cc Two Phase: 1,000 pulses/cc, 4x decoded (250 pulses/cc/phase, 1x decoded)
Power Supply Requirements	5 - 26 Vdc, @ 30 mA
Ambient Operational Range	-40°C to 80°C, Single piece – Two piece to 110°C
Metered Liquid Temp Range (based on 20° ambient)	-40°C to 90°C, Standard model -40°C to 155°C, Two piece high temperature model -40°C to 225°C, Two piece ultra high temperature model
Compliance	CE Certified, Ex-proof version available with ATEX/IECEX II 2 G Ex db IIB Tx Gb as well as UL, cUL certification for Class 1, Division 1, Groups C and D, Tx

ANALOG TRANSMITTER

Output Signal	Any range of ± 10V or ± 20mA Linearized and damped with anti-dither protection.
Power Supply Requirements	Two Models: 12Vdc @ 90 mA, 24Vdc @ 45 mA
Ambient Operational Range	-40°C to 80°C, Single piece – Two piece to 110°C
Metered Liquid Temp Range (based on 20° ambient)	-40°C to 90°C, Standard model -40°C to 155°C, Two piece high temperature model -40°C to 225°C, Two piece, ultra high temperature model
Compliance	CE Certified, Ex-proof version available with ATEX/IECEX II 2 G Ex db IIB Tx Gb as well as UL, cUL certification for Class 1, Division 1, Groups C and D, Tx

Specifications

G004HZ SPECIFICATIONS

Flow Range	0.5 cc/min to 4 liters/min
Accuracy (at 30 cP)	± 0.3% of reading over a 100:1 range,
Maximum Operating Pressure	6000 psi (414 bar)
Weight	1.1 kg
Recommended Filtration	10 micron
Port Size(s)	1/8" NPT or Manifold Mount
Fluids	Most non-aqueous, hydrocarbon based fluids

MATERIALS OF CONSTRUCTION

External	Stainless Steel, type 316; type 17-4 Bolts
Wetted	Stainless Steel, type 316, 440C, 17-4
O-Rings	Standard: Viton® Optional: Teflon®, Perfluoroelastomer

FREQUENCY TRANSMITTER

Output Signal	Standard: 5 Vdc, single phase Optional: Quadrature 5 Vdc, two phase Current sinking, 20 mA max., single phase
K-Factor	Single Phase: 500 pulses/cc Two Phase: 1,000 pulses/cc, 4x decoded (250 pulses/cc/phase, 1x decoded)
Power Supply Requirements	5 - 26 Vdc, @ 30 mA
Ambient Operational Range	-40°C to 75°C, Single piece – Two piece to 110°C
Metered Liquid Temp Range (based on 20° ambient)	-40°C to 75°C, Standard model -40°C to 130°C, Two piece high temperature model
Compliance	CE Certified, Ex-proof version available with ATEX/IECEX II 2 G Ex db IIB Tx Gb as well as UL, cUL certification for Class 1, Division 1, Groups C and D, Tx

ANALOG TRANSMITTER

Output Signal	Any range of ± 10V or ± 20mA Linearized and damped with anti-dither protection.
Power Supply Requirements	Two Models: 12Vdc @ 90 mA, 24Vdc @ 45 mA
Ambient Operational Range	-40°C to 75°C, Single piece – Two piece to 110°C
Metered Liquid Temp Range (based on 20° ambient)	-40°C to 75°C, Standard model -40°C to 130°C, Two piece high temperature model
Compliance	CE Certified, Ex-proof version available with ATEX/IECEX II 2 G Ex db IIB Tx Gb as well as UL, cUL certification for Class 1, Division 1, Groups C and D, Tx

Specifications

G015 SPECIFICATIONS

Flow Range	10 cc/min to 15 liters/min
Accuracy (at 30 cP)	± 0.3% of reading over a 100:1 range
Maximum Operating Pressure	6000 psi (414 bar)
Weight	1.8 kg
Recommended Filtration	10 micron
Port Size(s)	3/8" NPT or #6 SAE or Manifold Mount
Fluids	Most non-aqueous, hydrocarbon based fluids

MATERIALS OF CONSTRUCTION

External	Stainless steel, type 303; Fluoropolymer coated bolts; MoS2 lubricant
Wetted	Stainless steel, type 303, 440C, 17-4
O-Rings	Standard, Viton® Optional: Teflon®, Perfluoroelastomer

FREQUENCY TRANSMITTER

Output Signal	Standard: 5 Vdc, single phase Optional: Quadrature 5 Vdc, two phase Current sinking, 20 mA max., single phase
---------------	---

K-Factor	Single Phase: 200 pulses/cc Two Phase: 400 pulses/cc, 4x decoded (100 pulses/cc/phase, 1x decoded)
Power Supply Requirements	5 - 26 Vdc, @ 30 mA
Ambient Operational Range	-40°C to 80°C, Single piece – Two piece to 110°C
Metered Liquid Temp Range (based on 20° ambient)	-40°C to 90°C, Standard model -40°C to 155°C, Two piece high temperature model -40°C to 225°C, Two piece, ultra high temperature model
Compliance	CE Certified, Ex-proof version available with ATEX/IECEX II 2 G Ex db IIB Tx Gb as well as UL, cUL certification for Class 1, Division 1, Groups C and D, Tx

ANALOG TRANSMITTER

Output Signal	Any range of ± 10V or ± 20mA Linearized and damped with anti-dither protection.
Power Supply Requirements	Two Models: 12Vdc @ 90 mA, 24Vdc @ 45 mA
Ambient Operational Range	-40°C to 80°C, Single piece – Two piece to 110°C
Metered Liquid Temp Range (based on 20° ambient)	-40°C to 90°C, Standard model -40°C to 155°C, Two piece high temperature model -40°C to 225°C, Two piece, ultra high temperature model
Compliance	CE Certified, Ex-proof version available with ATEX/IECEX II 2 G Ex db IIB Tx Gb as well as UL, cUL certification for Class 1, Division 1, Groups C and D, Tx

Specifications

G015HZ SPECIFICATIONS

Flow Range	10 cc/min to 15 liters/min
Accuracy (at 30 cP)	± 0.3% of reading over a 100:1 range
Maximum Operating Pressure	6000 psi (414 bar)
Weight	1.8 kg
Recommended Filtration	10 micron
Port Size(s)	3/8" NPT or Manifold Mount
Fluids	Most non-aqueous, hydrocarbon based fluids

MATERIALS OF CONSTRUCTION

External	Stainless steel, type 316; type 17-4 Bolts
Wetted	Stainless steel, type 316, 440C, 17-4
O-Rings	Standard, Viton® Optional: Teflon®, Perfluoroelastomer

FREQUENCY TRANSMITTER

Output Signal	Standard: 5 Vdc, single phase Optional: Quadrature 5 Vdc, two phase Current sinking, 20 mA max., single phase
K-Factor	Single Phase: 200 pulses/cc Two Phase: 400 pulses/cc, 4x decoded (100 pulses/cc/phase, 1x decoded)
Power Supply Requirements	5 - 26 Vdc, @ 30 mA
Ambient Operational Range	-40°C to 75°C, Single piece – Two piece to 110°C
Metered Liquid Temp Range (based on 20° ambient)	-40°C to 75°C, Standard model -40°C to 130°C, Two piece high temperature model
Compliance	CE Certified, Ex-proof version available with ATEX/IECEX II 2 G Ex db IIB Tx Gb as well as UL, cUL certification for Class 1, Division 1, Groups C and D, Tx

ANALOG TRANSMITTER

Output Signal	Any range of ± 10V or ± 20mA Linearized and damped with anti-dither protection.
Power Supply Requirements	Two Models: 12Vdc @ 90 mA, 24Vdc @ 45 mA
Ambient Operational Range	-40°C to 75°C, Single piece – Two piece to 110°C
Metered Liquid Temp Range (based on 20° ambient)	-40°C to 75°C, Standard model -40°C to 130°C, Two piece high temperature model
Compliance	CE Certified, Ex-proof version available with ATEX/IECEX II 2 G Ex db IIB Tx Gb as well as UL, cUL certification for Class 1, Division 1, Groups C and D, Tx

Specifications

G045 SPECIFICATIONS

Flow Range	25 cc/min to 45 liters/min
Accuracy (at 30 cP)	± 0.3% of reading over a 100:1 range
Maximum Operating Pressure	6000 psi (414 bar)
Weight	3.7 kg
Recommended Filtration	30 micron
Port Size(s)	1/2" NPT or #8 SAE or Manifold Mount
Fluids	Most non-aqueous, hydrocarbon based fluids

MATERIALS OF CONSTRUCTION

External	Stainless steel, type 303; Fluoropolymer coated bolts; MoS2 lubricant
Wetted	Stainless steel, type 303, 440C, 17-4
O-Rings	Standard: Viton® Optional: Teflon®, Perfluoroelastomer

FREQUENCY TRANSMITTER

Output Signal	Standard: 5 Vdc, single phase Optional: Quadrature 5 Vdc, two phase Current sinking, 20 mA max., single phase
K-Factor	Single Phase: 70 pulses/cc Two Phase: 140 pulses/cc, 4x decoded (35 pulses/cc/phase, 1x decoded)
Power Supply Requirements	5 - 26 Vdc, @ 30 mA
Ambient Operational Range	-40°C to 80°C, Single piece – Two piece to 110°C
Metered Liquid Temp Range (based on 20° ambient)	-40°C to 90°C, Standard model -40°C to 155°C, Two piece high temperature model -40°C to 225°C, Two piece, ultra high temperature model
Compliance	CE Certified, Ex-proof version available with ATEX/IECEX II 2 G Ex db IIB Tx Gb as well as UL, cUL certification for Class 1, Division 1, Groups C and D, Tx

ANALOG TRANSMITTER

Output Signal	Any range of ± 10V or ± 20mA Linearized and damped with anti-dither protection.
Power Supply Requirements	Two Models: 12Vdc @ 90 mA, 24Vdc @ 45 mA
Ambient Operational Range	-40°C to 80°C, Single piece – Two piece to 110°C
Metered Liquid Temp Range (based on 20° ambient)	-40°C to 90°C, Standard model -40°C to 155°C, Two piece high temperature model -40°C to 225°C, Two piece, ultra high temperature model
Compliance	CE Certified, Ex-proof version available with ATEX/IECEX II 2 G Ex db IIB Tx Gb as well as UL, cUL certification for Class 1, Division 1, Groups C and D, Tx

Specifications

G045HZ SPECIFICATIONS

Flow Range	25 cc/min to 45 liters/min
Accuracy (at 30 cP)	± 0.3% of reading over a 100:1 range
Maximum Operating Pressure	6000 psi (414 bar)
Weight	3.7 kg
Recommended Filtration	30 micron
Port Size(s)	1/2" NPT or Manifold Mount
Fluids	Most non-aqueous, hydrocarbon based fluids

MATERIALS OF CONSTRUCTION

External	Stainless steel, type 316; type 17-4 Bolts
Wetted	Stainless steel, type 316, 440C, 17-4
O-Rings	Standard: Viton® Optional: Teflon®, Perfluoroelastomer

FREQUENCY TRANSMITTER

Output Signal	Standard: 5 Vdc, single phase Optional: Quadrature 5 Vdc, two phase Current sinking, 20 mA max., single phase
K-Factor	Single Phase: 70 pulses/cc Two Phase: 140 pulses/cc, 4x decoded (35 pulses/cc/phase, 1x decoded)
Power Supply Requirements	5 - 26 Vdc, @ 30 mA
Ambient Operational Range	-40°C to 75°C, Single piece – Two piece to 110°C
Metered Liquid Temp Range (based on 20° ambient)	-40°C to 75°C, Standard model -40°C to 130°C, Two piece high temperature model
Compliance	CE Certified, Ex-proof version available with ATEX/IECEX II 2 G Ex db IIB Tx Gb as well as UL, cUL certification for Class 1, Division 1, Groups C and D, Tx

ANALOG TRANSMITTER

Output Signal	Any range of ± 10V or ± 20mA Linearized and damped with anti-dither protection.
Power Supply Requirements	Two Models: 12Vdc @ 90 mA, 24Vdc @ 45 mA
Ambient Operational Range	-40°C to 75°C, Single piece – Two piece to 110°C
Metered Liquid Temp Range (based on 20° ambient)	-40°C to 75°C, Standard model -40°C to 130°C, Two piece high temperature model
Compliance	CE Certified, Ex-proof version available with ATEX/IECEX II 2 G Ex db IIB Tx Gb as well as UL, cUL certification for Class 1, Division 1, Groups C and D, Tx

Specifications

G105 SPECIFICATIONS

Flow Range	75 cc/min to 105 liters/min
Accuracy (at 30 cP)	± 0.3% of reading over a 100:1 range
Maximum Operating Pressure	6000 psi (414 bar)
Weight	7.7 kg
Recommended Filtration	30 micron
Port Size(s)	3/4" NPT or #10 SAE
Fluids	Most non-aqueous, hydrocarbon based fluids

MATERIALS OF CONSTRUCTION

External	Stainless steel, type 303; Fluoropolymer coated bolts; MoS2 lubricant
Wetted	Stainless steel, type 303, 440C, 17-4
O-Rings	Standard, Viton® Optional: Teflon®, Perfluoroelastomer

FREQUENCY TRANSMITTER

Output Signal	Standard: 5 Vdc, single phase Optional: Quadrature 5 Vdc, two phase Current sinking, 20 mA max., single phase
K-Factor	Single Phase: 25 pulses/cc Two Phase: 50 pulses/cc, 4x decoded (12.5 pulses/cc/phase, 1x decoded)
Power Supply Requirements	5 - 26 Vdc, @ 30 mA
Ambient Operational Range	-40°C to 80°C, Single piece – Two piece to 110°C
Metered Liquid Temp Range (based on 20° ambient)	-40°C to 90°C, Standard model -40°C to 155°C, Two piece high temperature model -40°C to 225°C, Two piece, ultra high temperature model
Compliance	CE Certified, Ex-proof version available with ATEX/IECEX II 2 G Ex db IIB Tx Gb as well as UL, cUL certification for Class 1, Division 1, Groups C and D, Tx

ANALOG TRANSMITTER

Output Signal	Any range of ± 10V or ± 20mA Linearized and damped with anti-dither protection.
Power Supply Requirements	Two Models: 12Vdc @ 90 mA, 24Vdc @ 45 mA
Ambient Operational Range	-40°C to 80°C, Single piece – Two piece to 110°C
Metered Liquid Temp Range (based on 20° ambient)	-40°C to 90°C, Standard model -40°C to 155°C, Two piece high temperature model -40°C to 225°C, Two piece, ultra high temperature model
Compliance	CE Certified, Ex-proof version available with ATEX/IECEX II 2 G Ex db IIB Tx Gb as well as UL, cUL certification for Class 1, Division 1, Groups C and D, Tx

Specifications

G240 SPECIFICATIONS

Flow Range	250 cc/min to 240 liters/min
Accuracy (at 30 cP)	± 0.3% of reading over a 100:1 range
Maximum Operating Pressure	4000 psi (275 bar) - NPT fittings 6000 psi (414 bar) - SAE fittings
Weight	21 kg
Recommended Filtration	30 micron
Port Size(s)	1" NPT or #16 SAE
Fluids	Most non-aqueous, hydrocarbon based fluids

MATERIALS OF CONSTRUCTION

Body	Stainless steel, type 303; Fluoropolymer coated bolts; MoS2 lubricant
Gears and Shafts	Stainless steel, type 303, 440C, 17-4
O-Rings	Standard, Viton® Optional: Teflon®, Perfluoroelastomer

FREQUENCY TRANSMITTER

Output Signal	Standard: 5 Vdc, single phase Optional: Quadrature 5 Vdc, two phase Current sinking, 20 mA max., single phase
K-Factor	Single Phase: 7 pulses/cc Two Phase: 14 pulses/cc, 4x decoded (3.5 pulses/cc/phase, 1x decoded)
Power Supply Requirements	5 - 26 Vdc, @ 30 mA
Ambient Operational Range	-40°C to 80°C, Single piece – Two piece to 110°C
Metered Liquid Temp Range (based on 20° ambient)	-40°C to 90°C, Standard model -40°C to 155°C, Two piece high temperature model -40°C to 225°C, Two piece, ultra high temperature model
Compliance	CE Certified, Ex-proof version available with ATEX/IECEX II 2 G Ex db IIB Tx Gb as well as UL, cUL certification for Class 1, Division 1, Groups C and D, Tx

ANALOG TRANSMITTER

Output Signal	Any range of ± 10V or ± 20mA Linearized and damped with anti-dither protection.
Power Supply Requirements	Two Models: 12Vdc @ 90 mA, 24Vdc @ 45 mA
Ambient Operational Range	-40°C to 80°C, Single piece – Two piece to 110°C
Metered Liquid Temp Range (based on 20° ambient)	-40°C to 90°C, Standard model -40°C to 155°C, Two piece high temperature model -40°C to 225°C, Two piece, ultra high temperature model
Compliance	CE Certified, Ex-proof version available with ATEX/IECEX II 2 G Ex db IIB Tx Gb as well as UL, cUL certification for Class 1, Division 1, Groups C and D, Tx

Dimensions

G004 SPECIFICATIONS

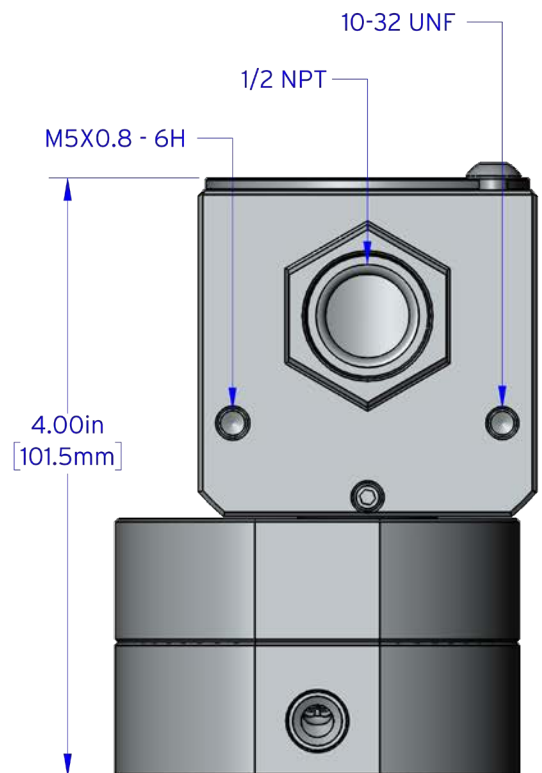
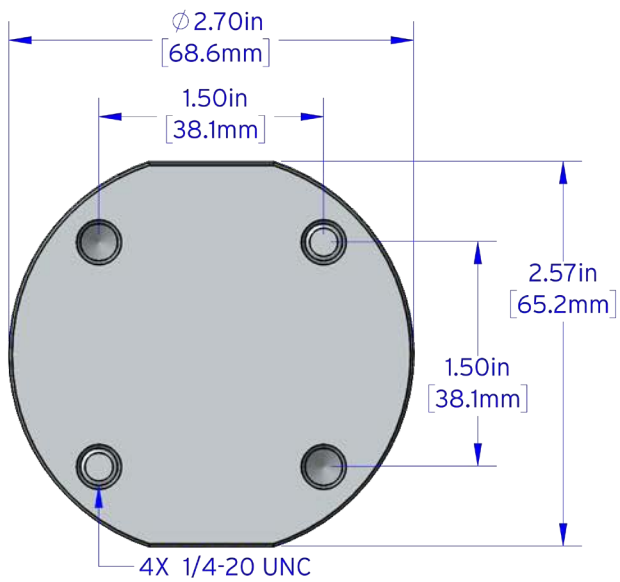
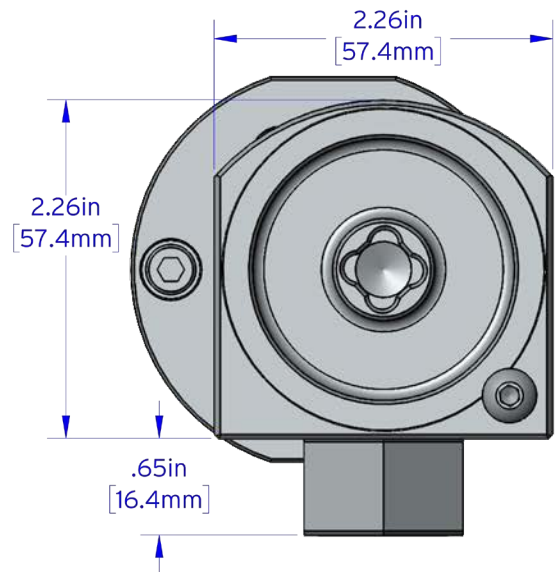
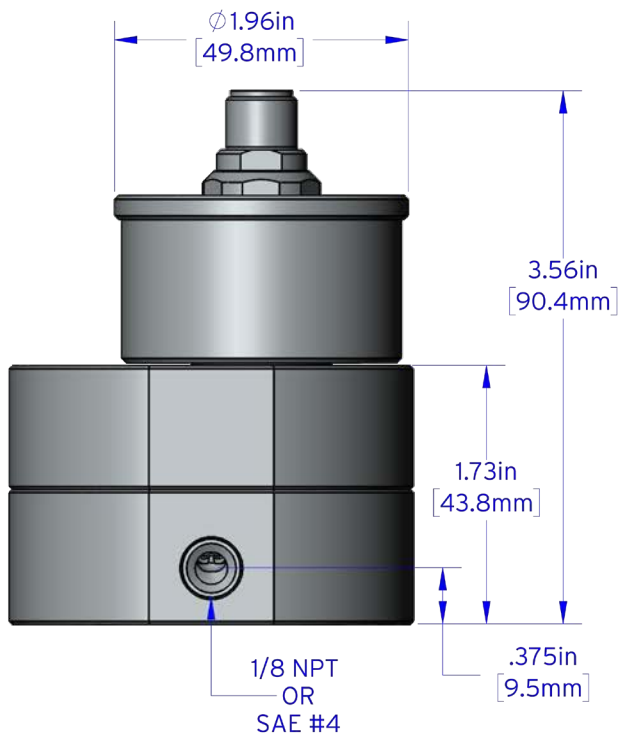

Dimensions

G004HZ SPECIFICATIONS

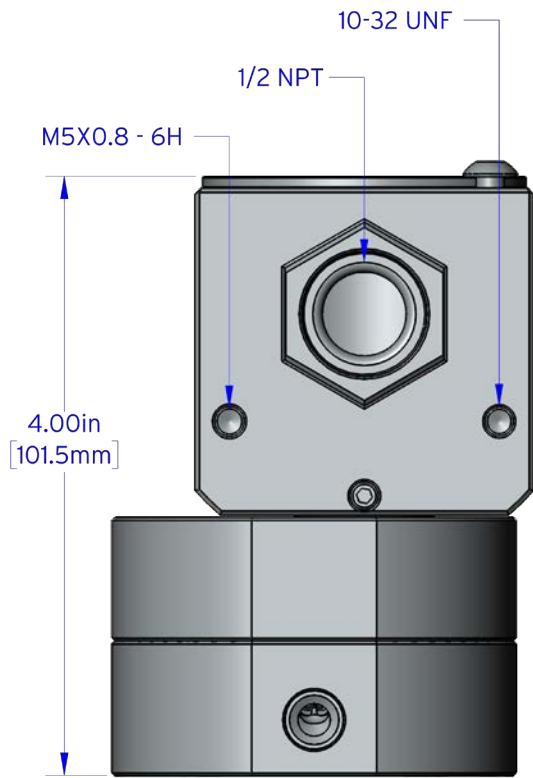

MODEL G004HZ WITH
EX-PROOF HOUSING

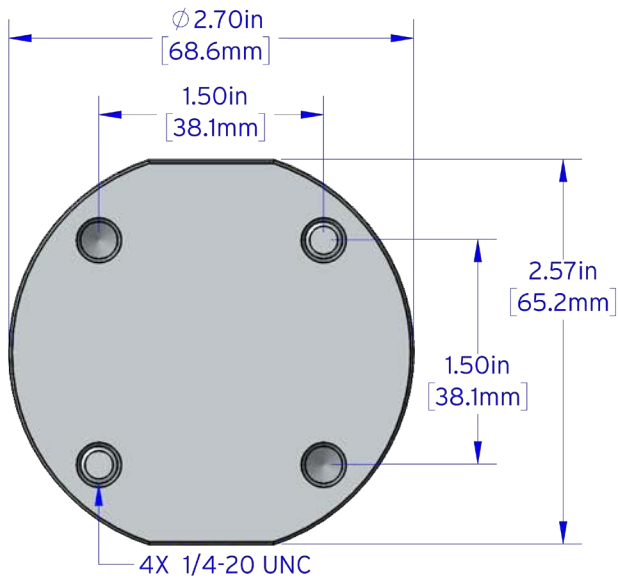
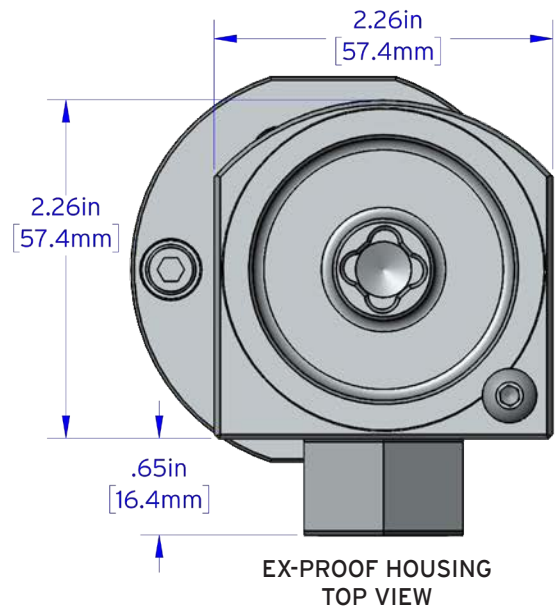

Dimensions

G004 SPECIFICATIONS - MANIFOLD

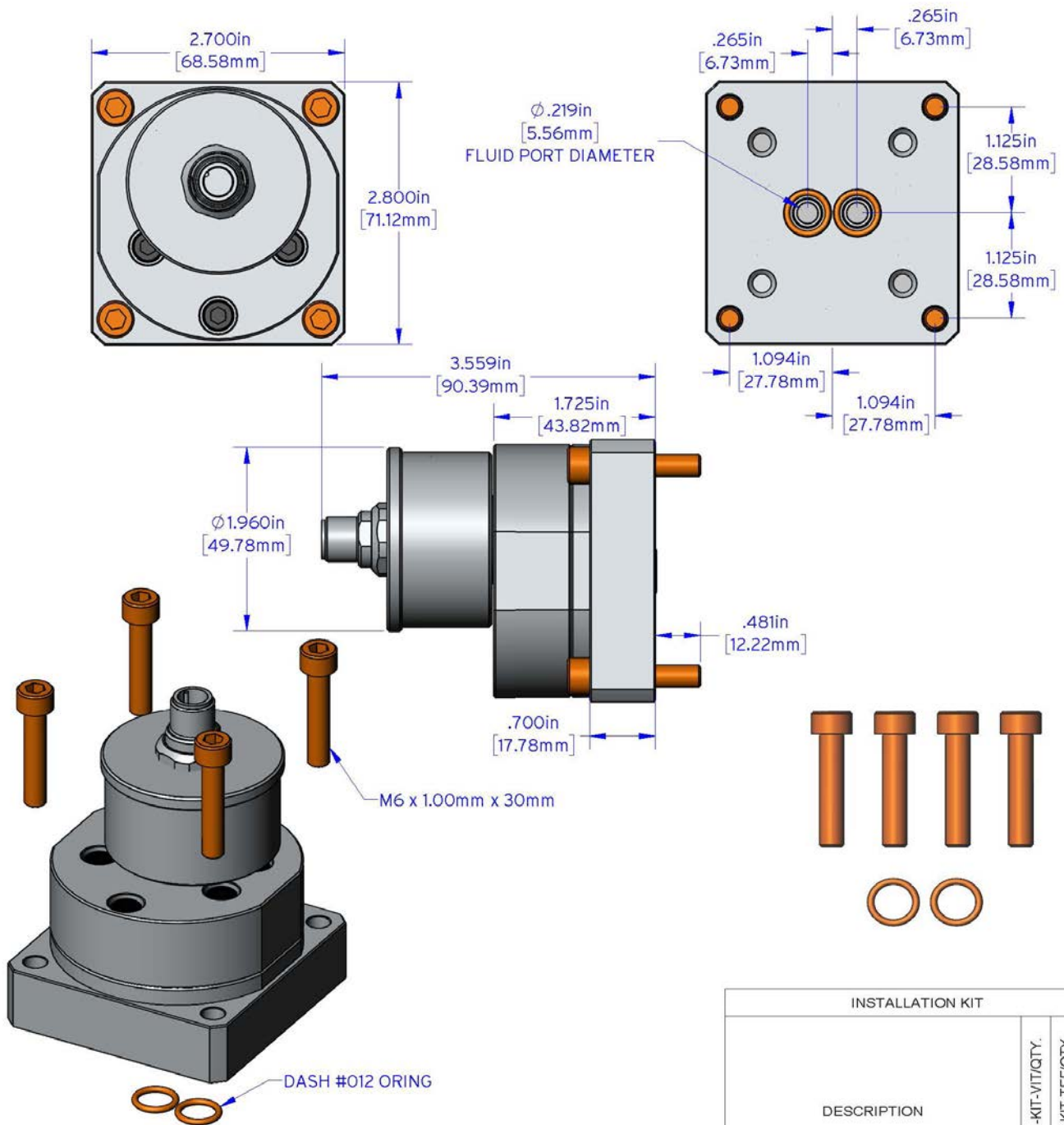

INSTALLATION KIT			
DESCRIPTION	G004-MM-KIT-VIT/QTY.	G004-MM-KIT-TEF/QTY.	G004-MM-KIT-PER/QTY.
SHCS M6x1x30 COATED	4	4	4
O-RING 90 FKM 3/8X1/2X1/16	2	-	-
O-RING PTFE 3/8X1/2x1/16	-	2	-
O-RING 90 FFKM 3/8X1/2X1/16	-	-	2

Dimensions

G004HZ SPECIFICATIONS - MANIFOLD

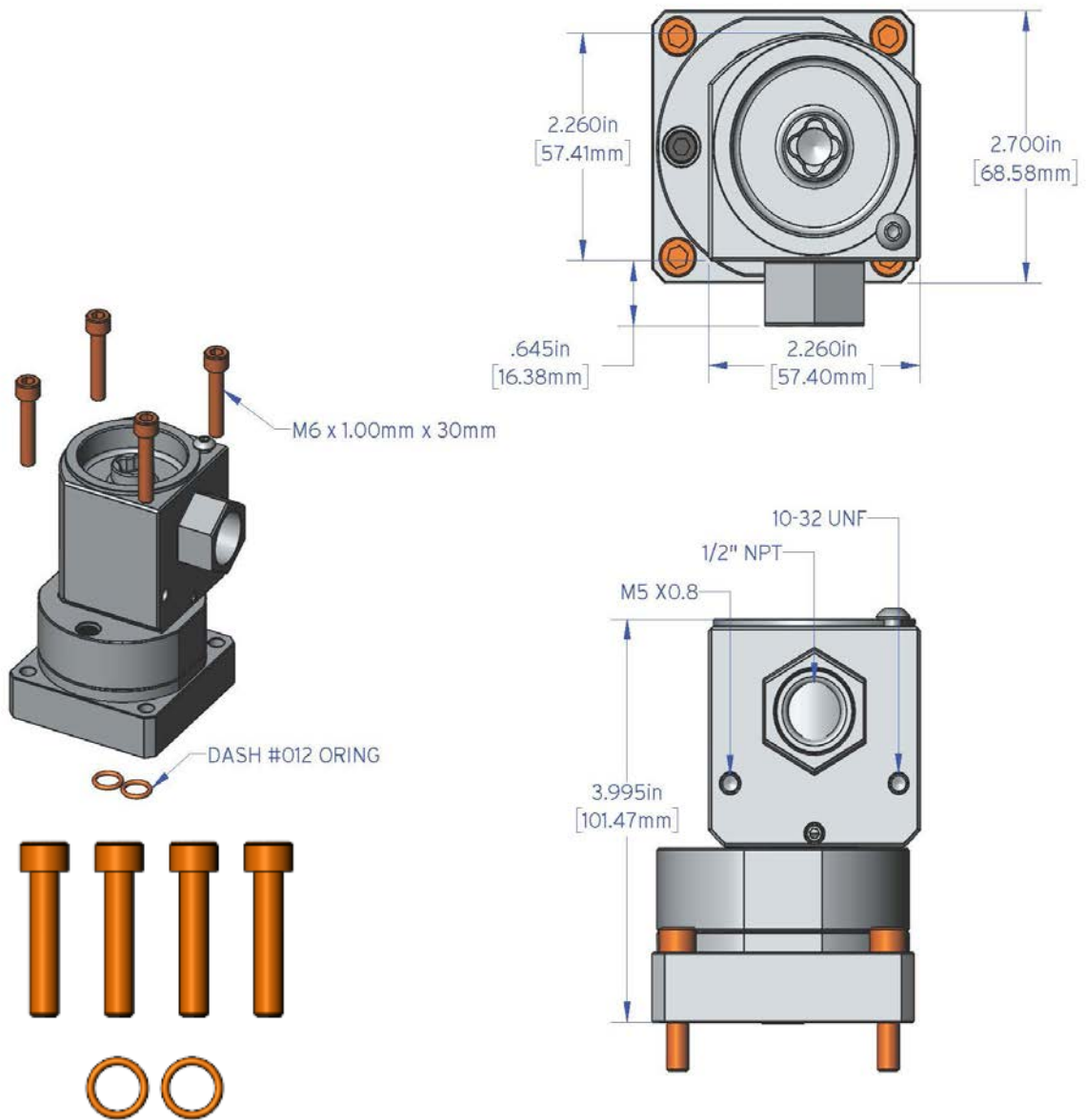

INSTALLATION KIT			
DESCRIPTION	G004-MM-KIT-VIT-S/QTY.	G004-MM-KIT-TEF-S/QTY.	G004-MM-KIT-PER-S/QTY.
SHCS M6x1x30 17-4	4	4	4
O-RING 90 FKM 3/8X1/2X1/16	2	-	-
O-RING PTFE 3/8X1/2X1/16	-	2	-
O-RING 90 FFKM 3/8X1/2X1/16	-	-	2

Dimensions

G015 SPECIFICATIONS

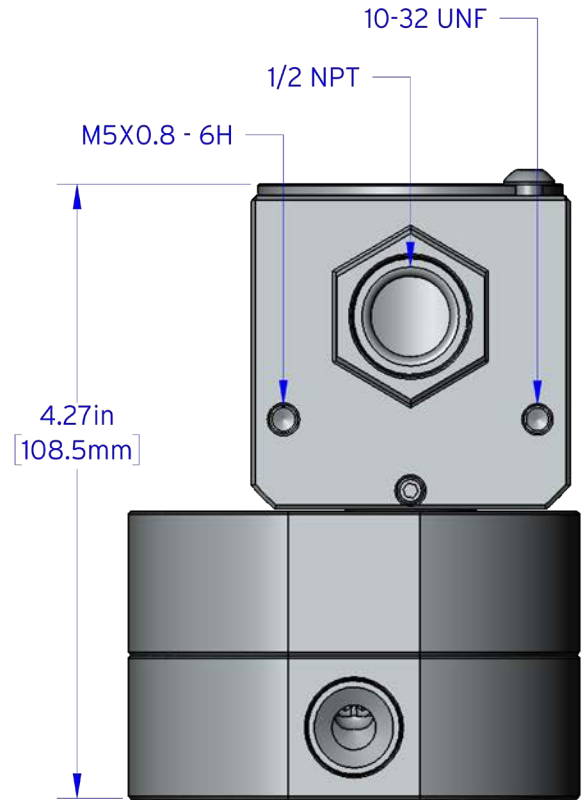
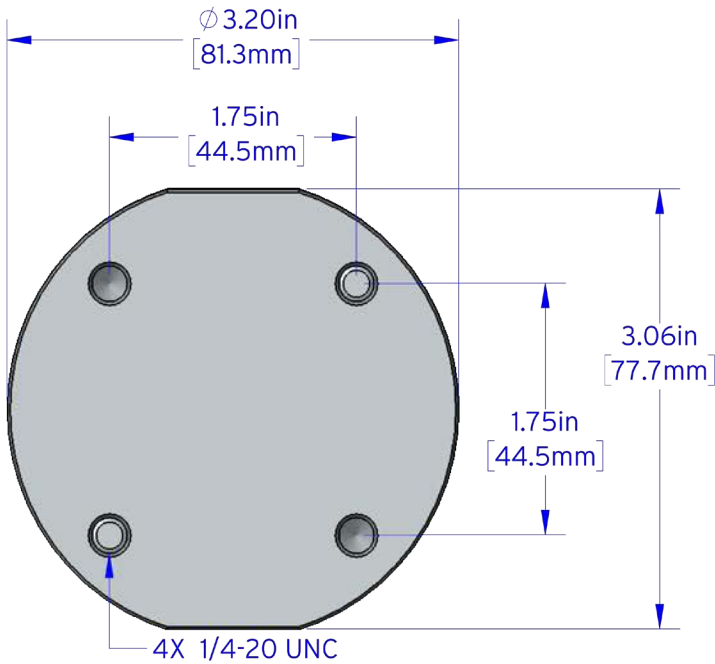
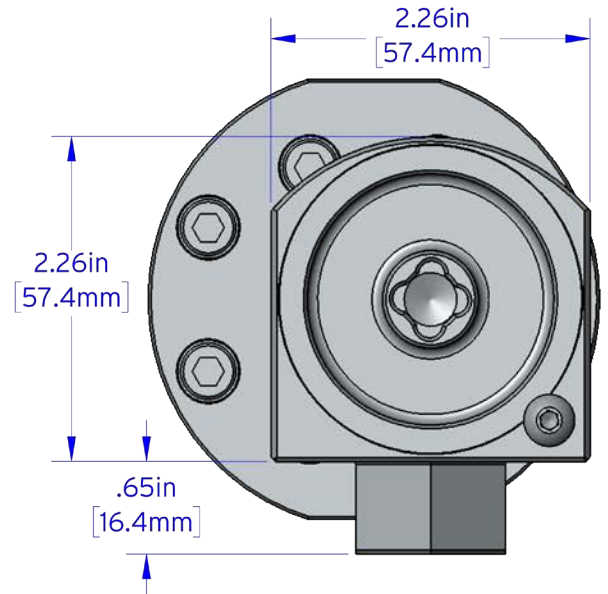
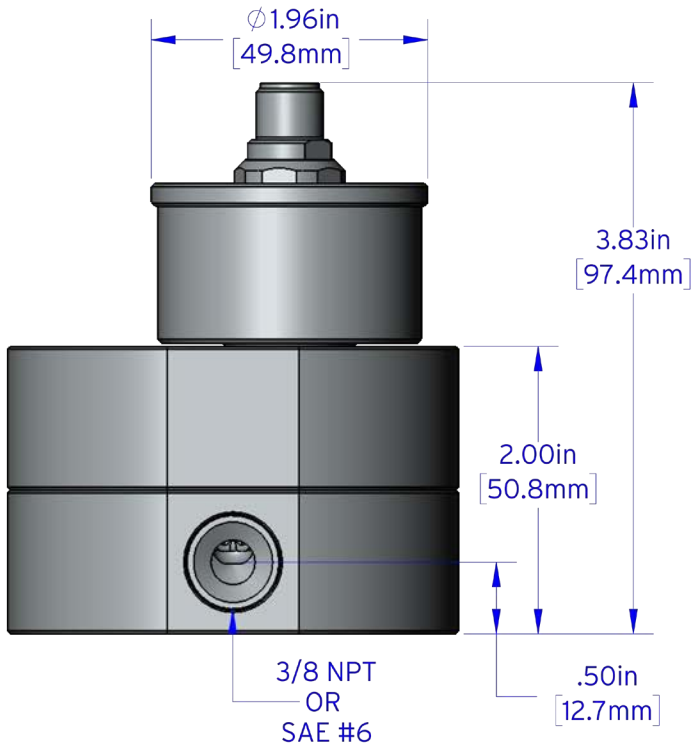

Dimensions

G015HZ SPECIFICATIONS

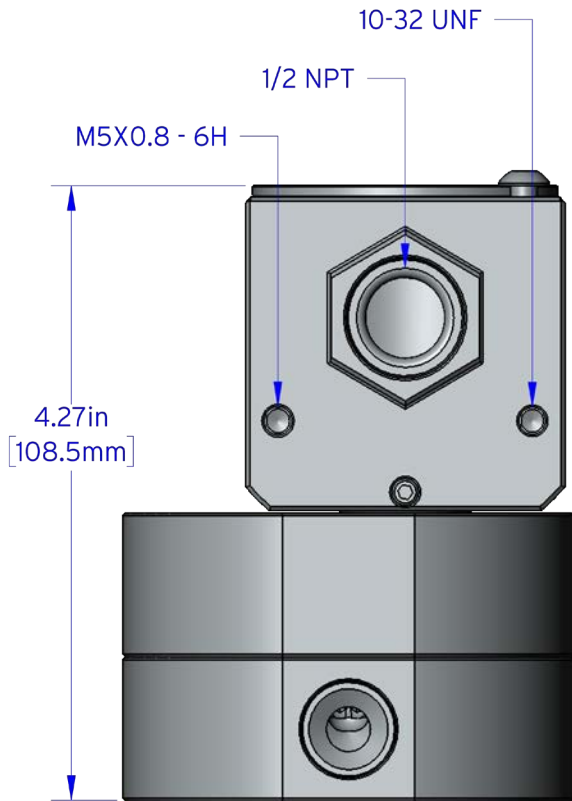

MODEL G015HZ WITH EX-PROOF HOUSING

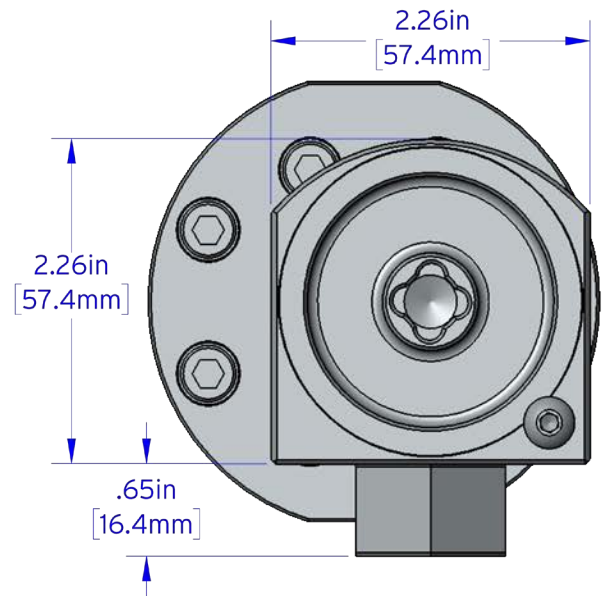

EX-PROOF HOUSING TOP VIEW

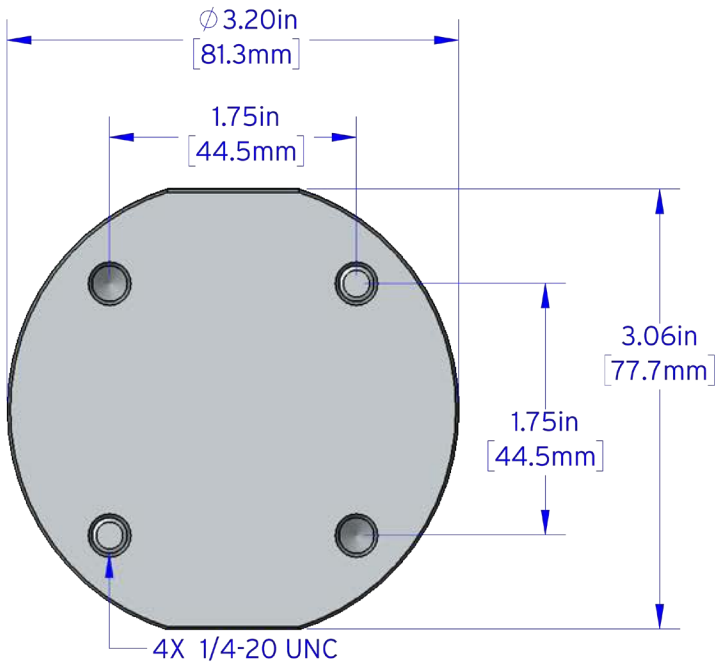

Dimensions

G015 SPECIFICATIONS - MANIFOLD

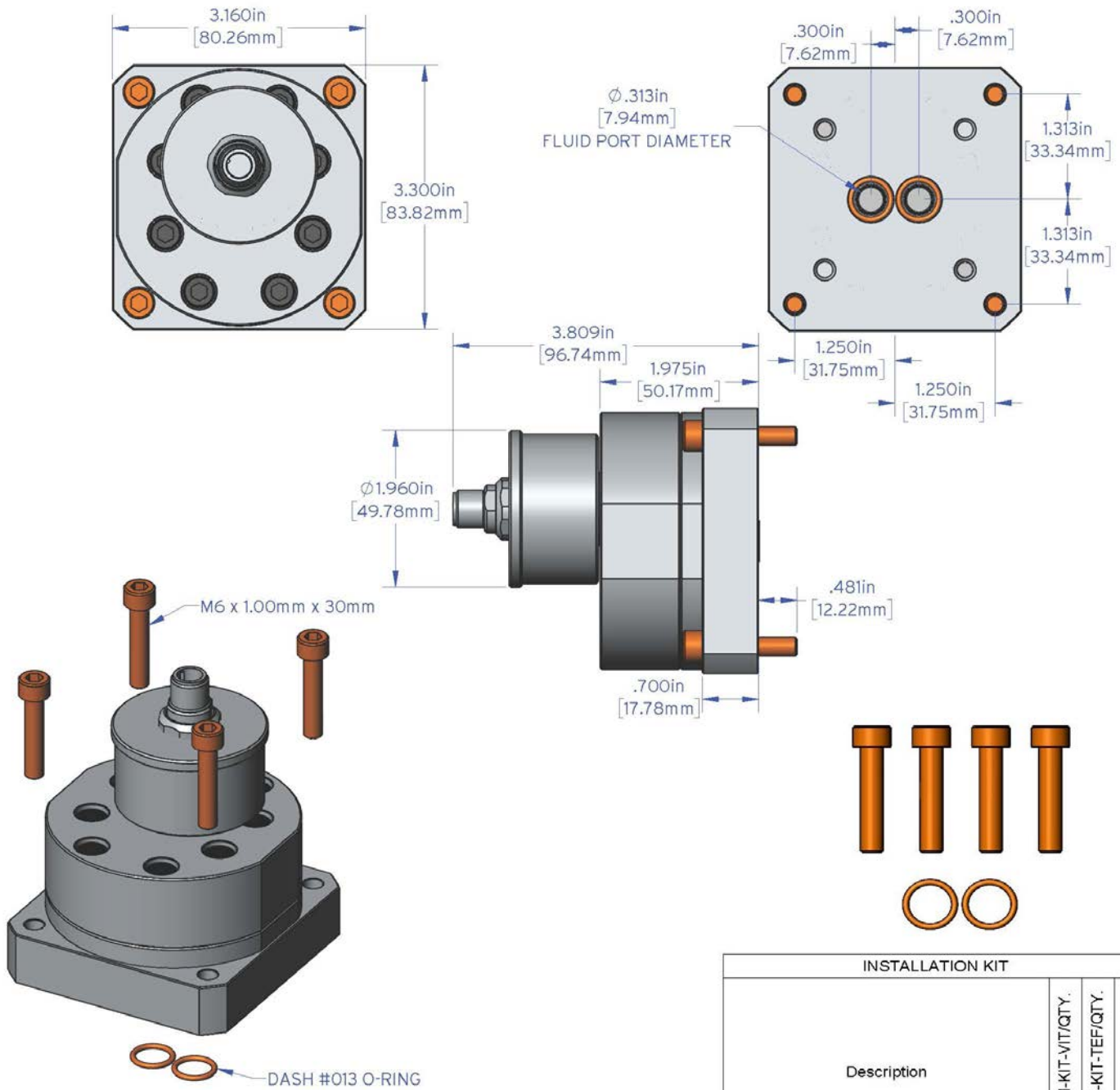

INSTALLATION KIT			
Description	G015-MM-KIT-VIT/QTY.	G015-MM-KIT-TEF/QTY.	G015-MM-KIT-PER/QTY.
SHCS M6x1x30 COATED	4	4	4
O-RING 90 FKM 7/16x9/16x1/16	2	-	-
O-RING PTFE 7/16x9/16x1/16	-	2	-
O-RING 90 FFKM 7/16x9/16x1/16	-	-	2

Dimensions

G015HZ SPECIFICATIONS - MANIFOLD

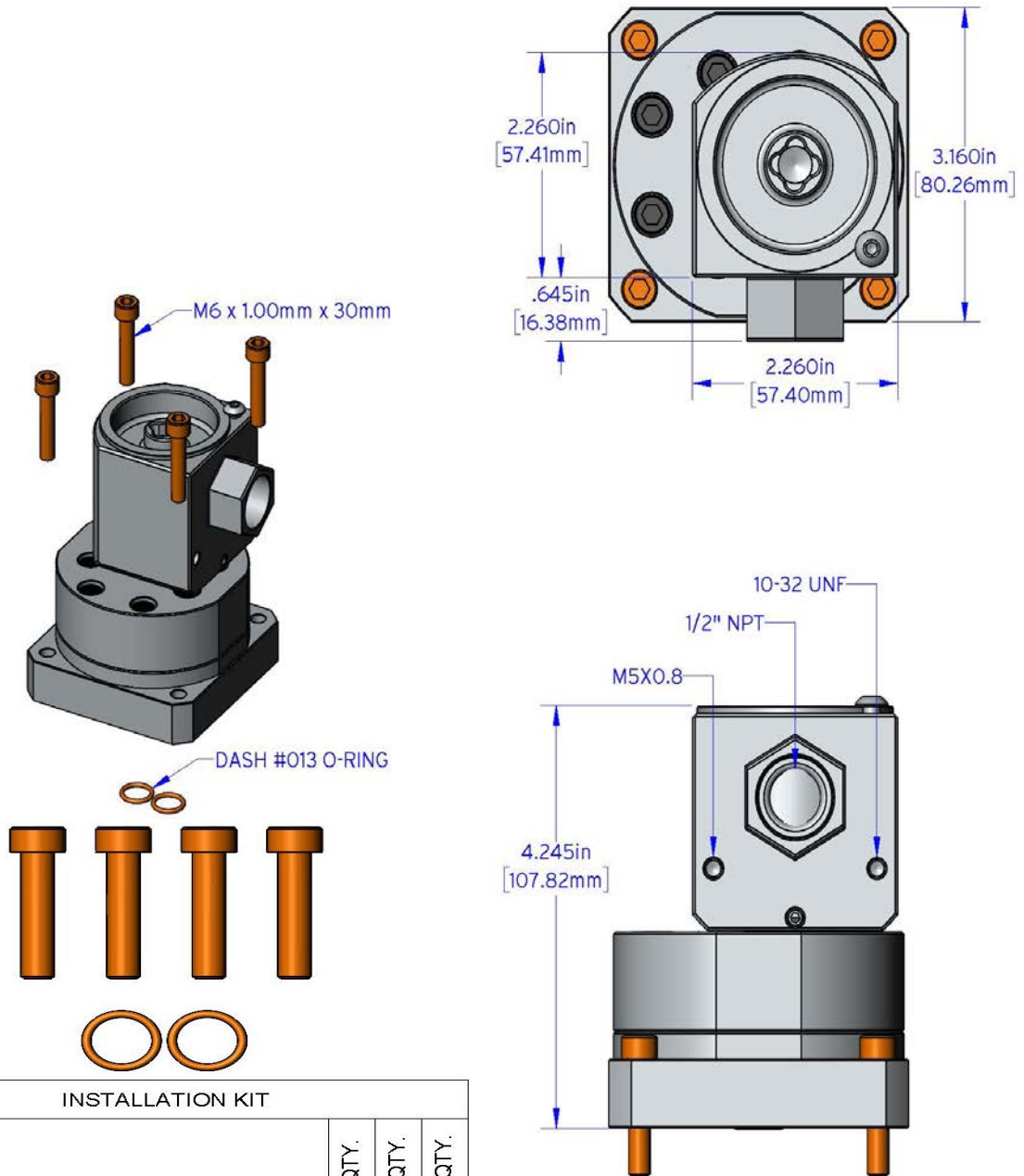

INSTALLATION KIT			
Description	G015-MM-KIT-VIT-S/QTY.	G015-MM-KIT-TEF-S/QTY.	G015-MM-KIT-PER-S/QTY.
SHCS M6x1x30 17-4	4	4	4
O-RING 90 FKM 7/16x9/16x1/16	2	-	-
O-RING PTFE 7/16x9/16x1/16	-	2	-
O-RING 90 FFKM 7/16x9/16x1/16	-	-	2

Dimensions

G045 SPECIFICATIONS

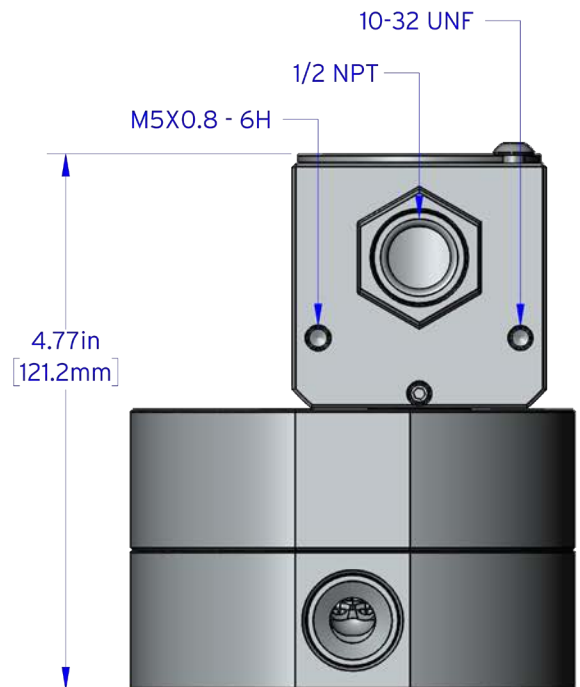
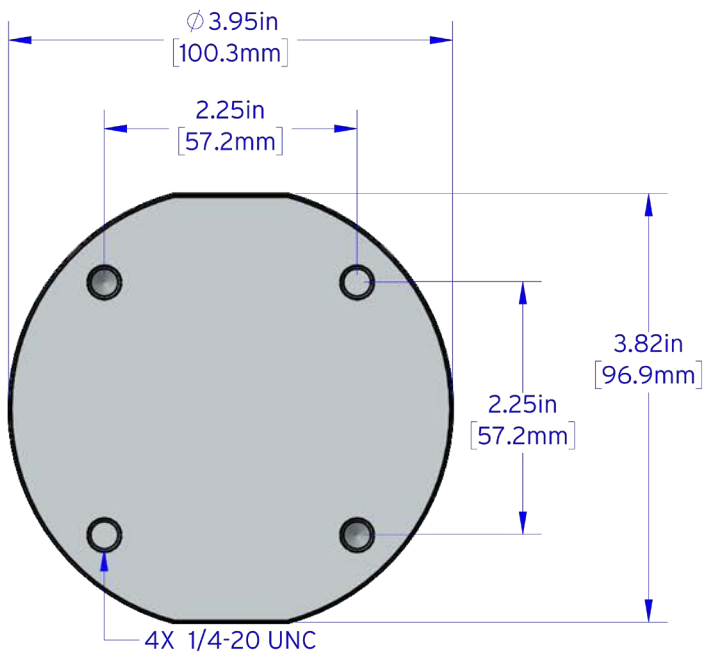
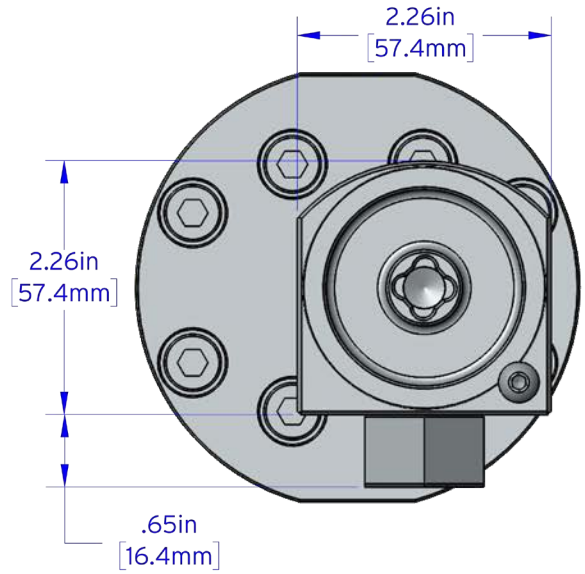
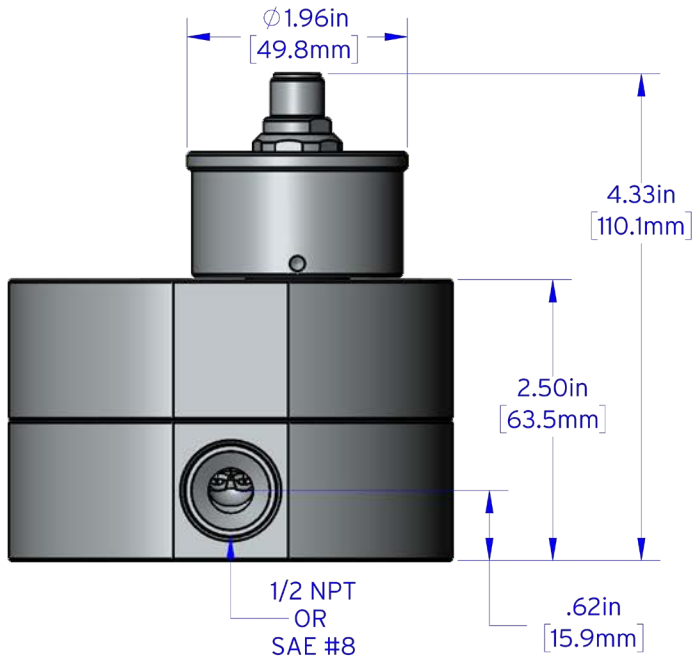

Dimensions

G045HZ SPECIFICATIONS

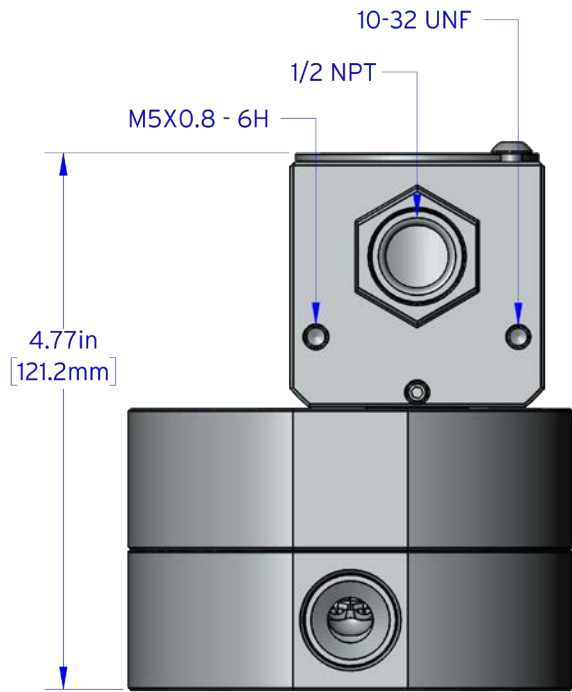

MODEL G045HZ WITH
EX-PROOF HOUSING

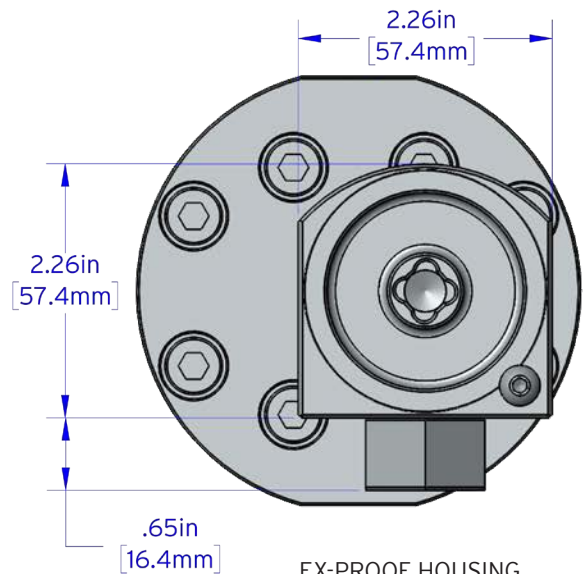

EX-PROOF HOUSING
TOP VIEW

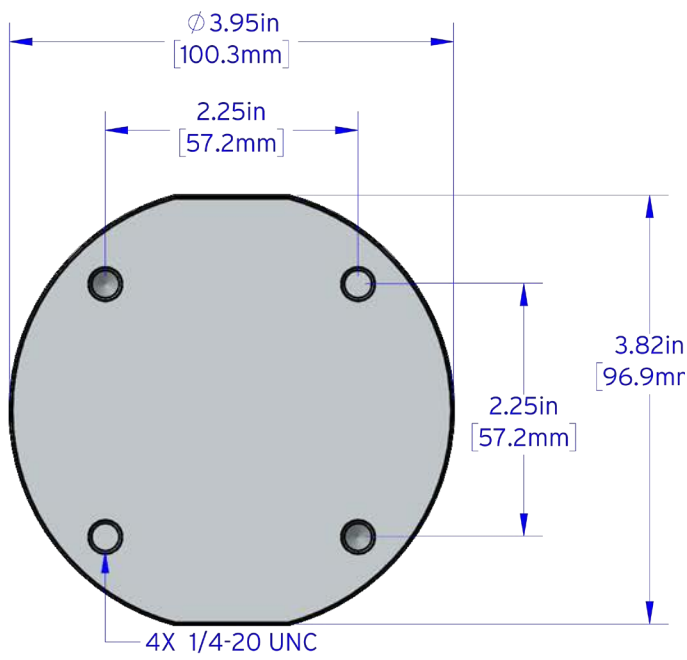

BOTTOM VIEW

Dimensions

G045 SPECIFICATIONS - MANIFOLD

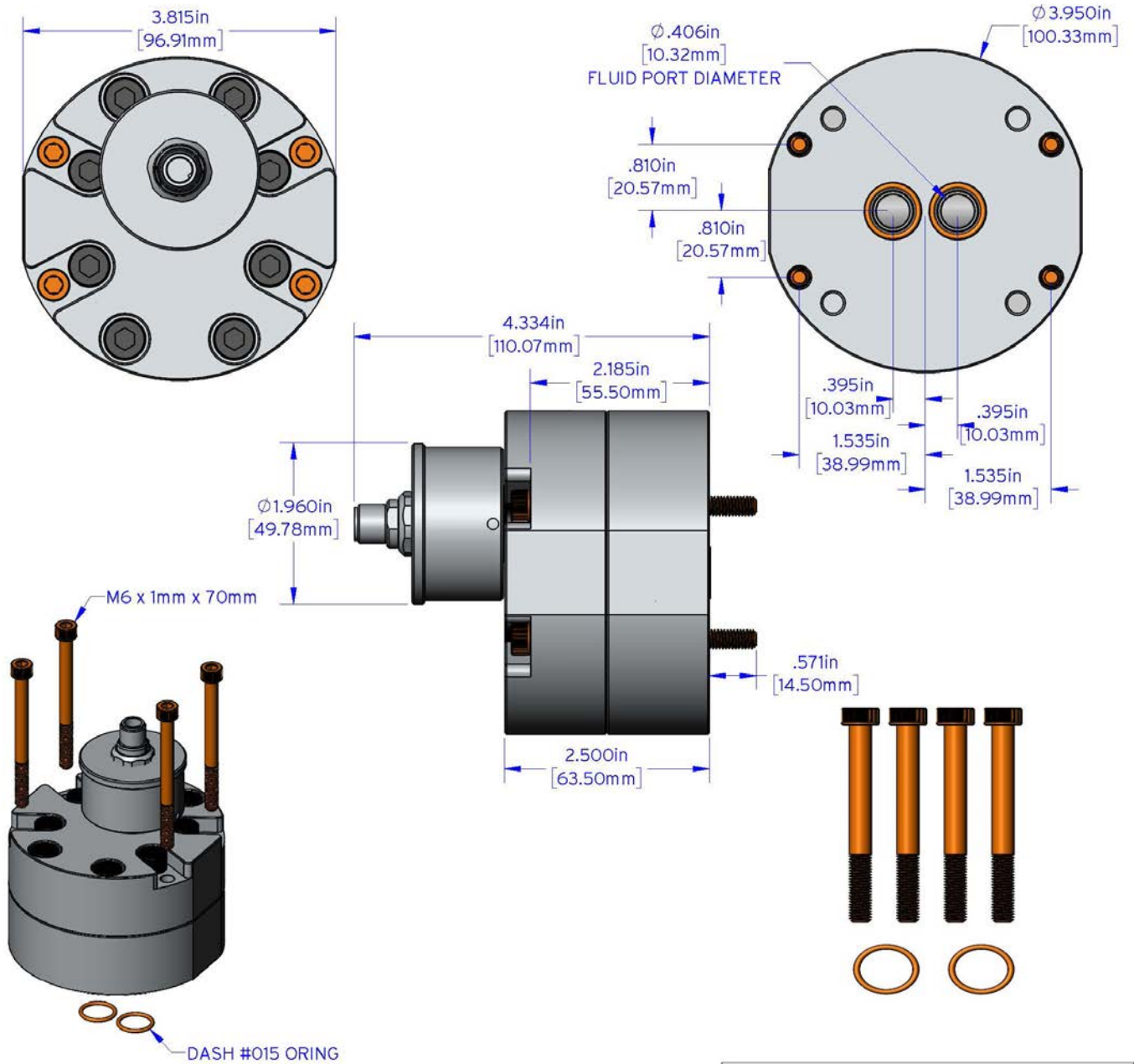

INSTALLATION KIT			
Description	G045-MM-KIT-VIT/QTY.	G045-MM-KIT-TEF/QTY.	G045-MM-KIT-PER/QTY.
SHCS M6x1x70 COATED	4	4	4
O-RING 90 FKM 9/16X11/16X1/16	2	-	-
O-RING PTFE 9/16X11/16X1/16	-	2	-
O-RING 90 FFKM 9/16X11/16X1/16	-	-	2

Dimensions

G045HZ SPECIFICATIONS - MANIFOLD

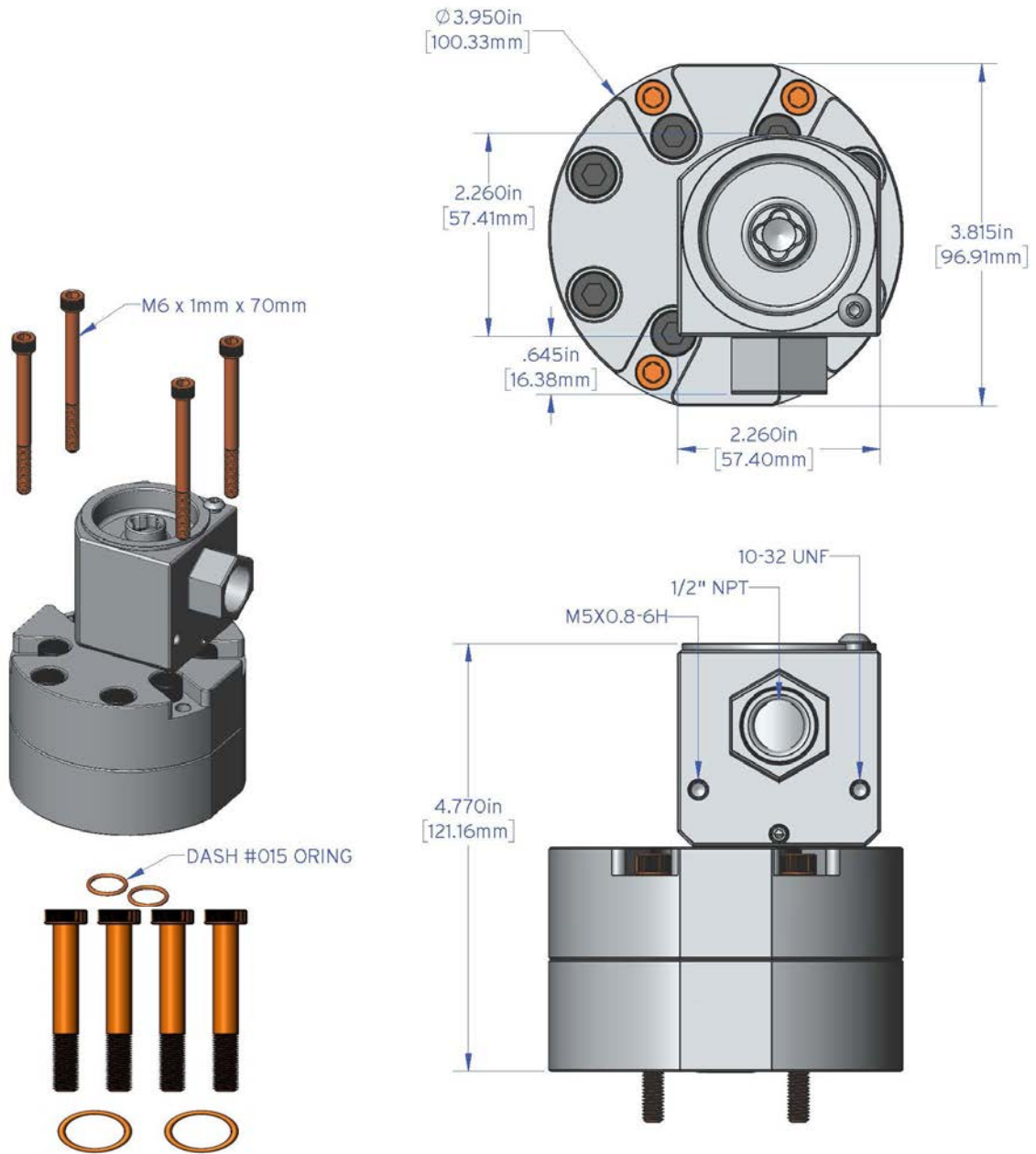

INSTALLATION KIT			
Description	G045-MM-KIT-VIT-S/QTY.	G045-MM-KIT-TEF-S/QTY.	G045-MM-KIT-PER-S/QTY.
SHCS M6x1x70 17-4	4	4	4
O-RING 90 FKM 9/16X11/16X1/16	2	-	-
O-RING PTFE 9/16X11/16X1/16	-	2	-
O-RING 90 FFKM 9/16X11/16X1/16	-	-	2

Dimensions

G105 SPECIFICATIONS

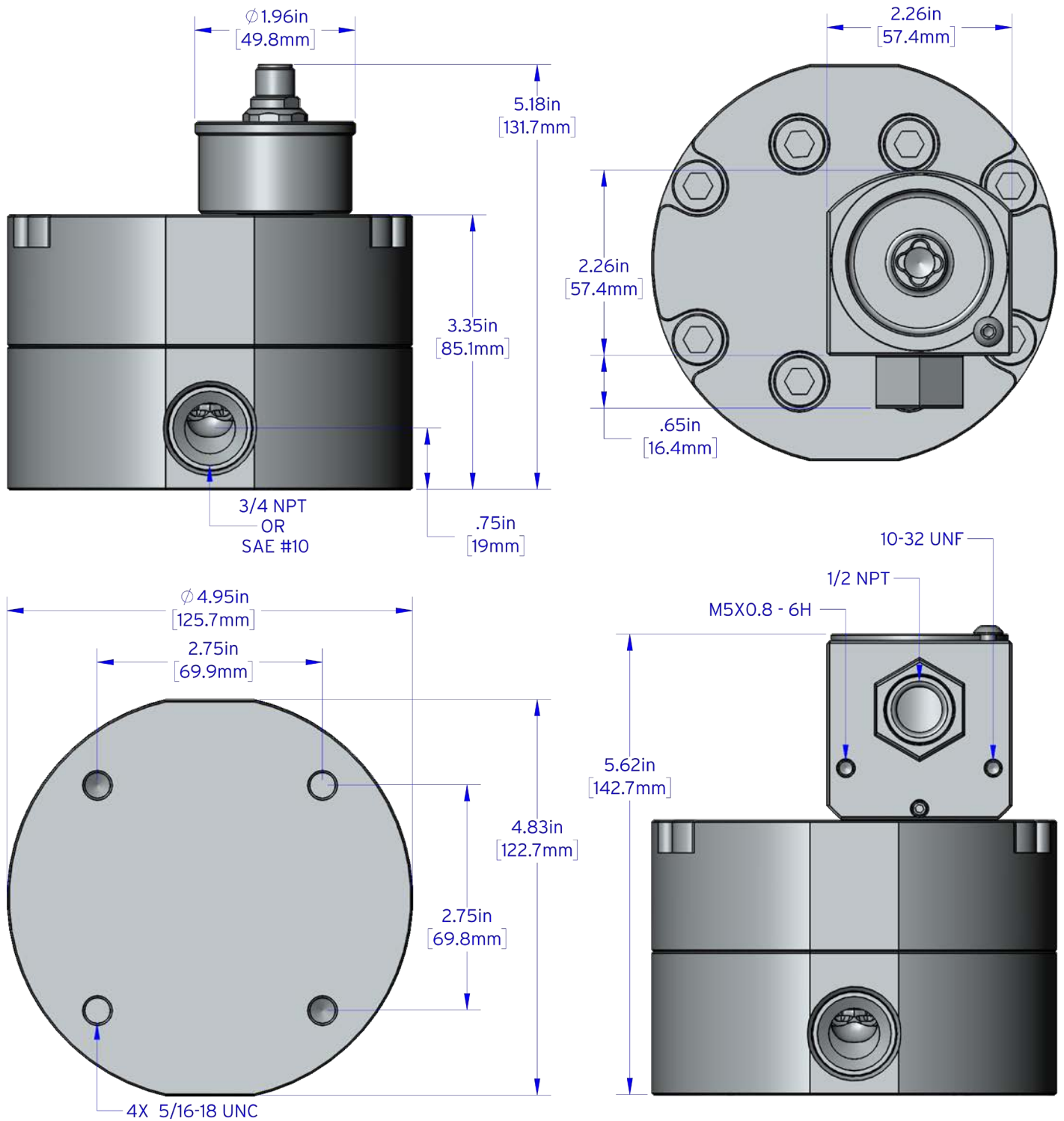

Dimensions

G240 SPECIFICATIONS

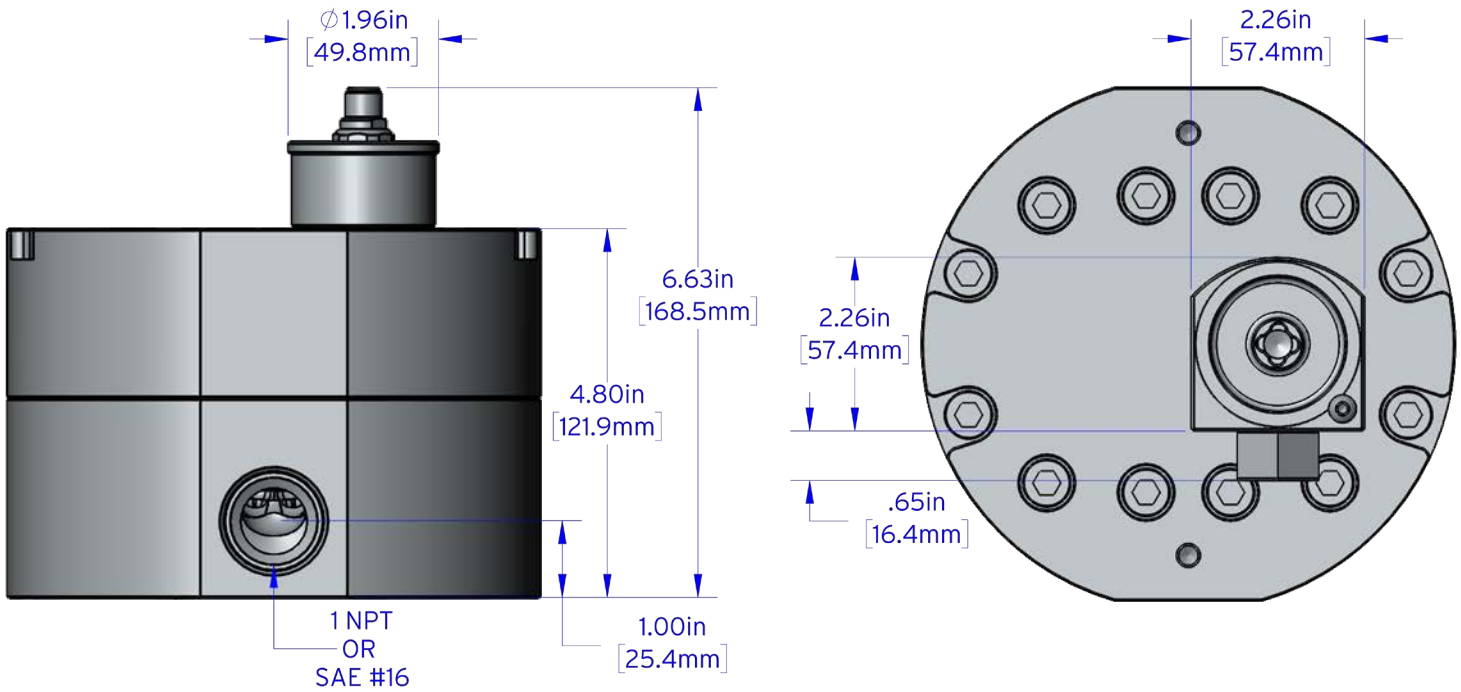

MODEL G240 WITH INDUSTRIAL HOUSING

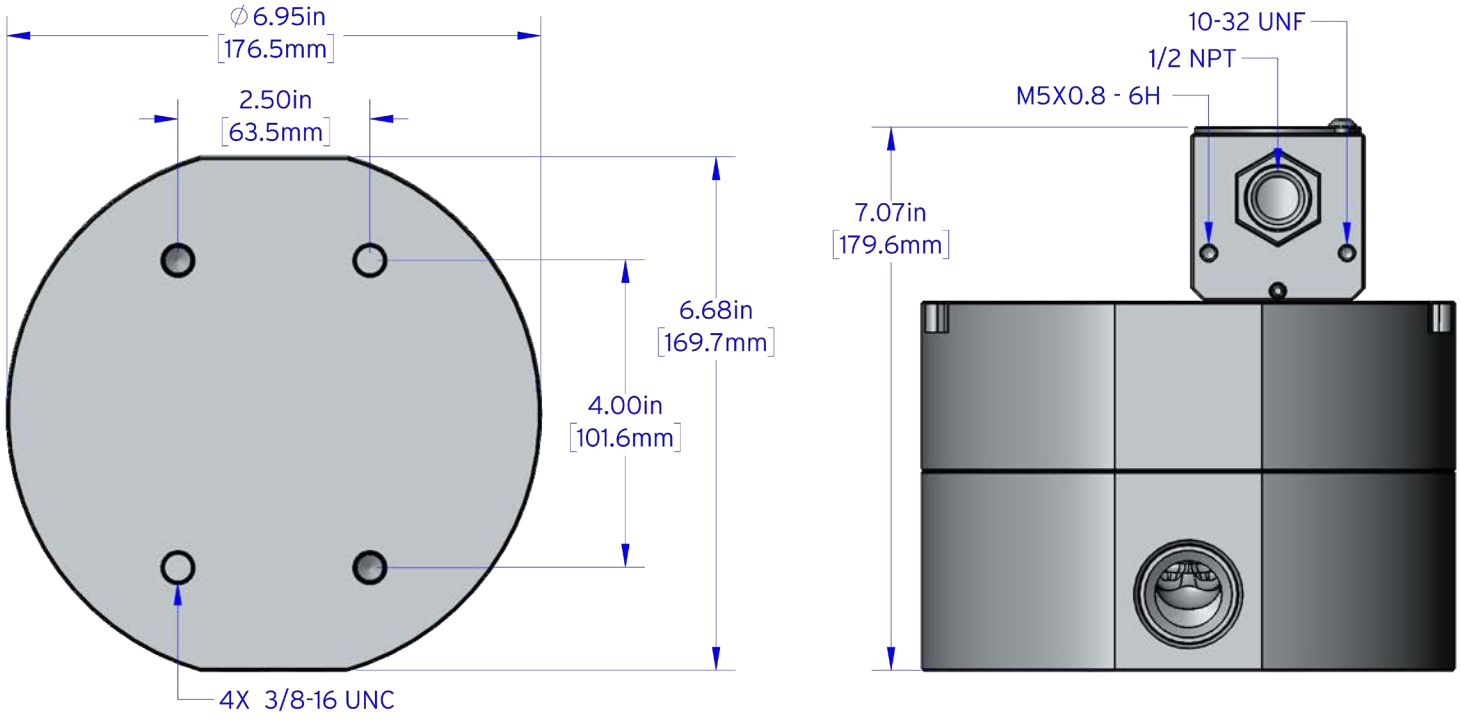

Dimensions

REMOTE PCA ENCLOSURE SPECIFICATIONS

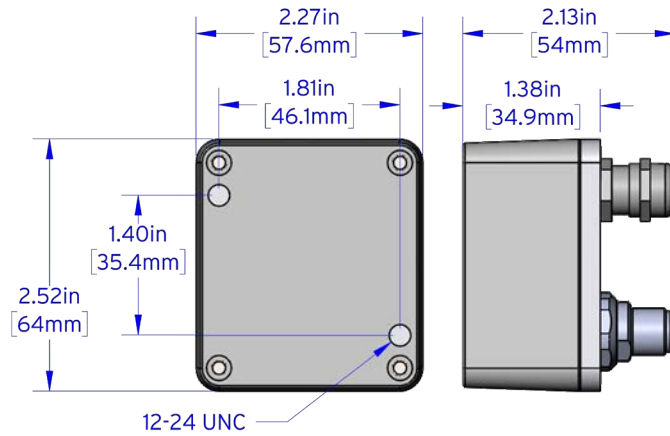

REMOTE PCA ENCLOSURE FOR HIGH
TEMPERATURE TRANSMITTERS
(Not Shown: Industrial 2 meter interconnect cable included,
Ex-Proof user supplied interconnect cable required)

Optional Heater Block

Temperature probe holes (all models)

1/8" NPT

1/16" NPT

Liquid trace ports

G004, G015 1/4" NPT

G045, G105 3/8" NPT

G240 (Qty 2) 3/8" NPT

Electric Cartridge requirements

G004 3/8" x 1"

G015 3/8" x 1.3"

G045 1/2" x 2.1"

G105 1/2" x 3.1"

G240 (Qty 2) 1/2" x 4.7"

Heater block for G015
(typical)

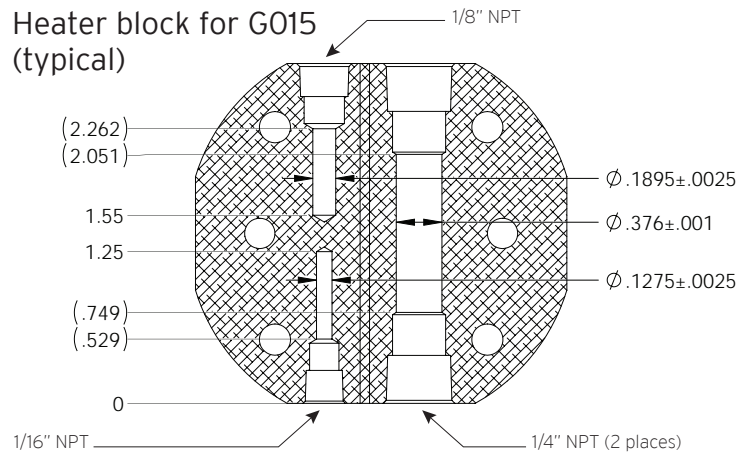

NOTES:

1: HEATER PORT CLEARANCE IS FOR A PROBE WITH 250 WATT/DENSITY MAX AT 400° F

Charts

G004 / G004HZ Pressure Drop Graph

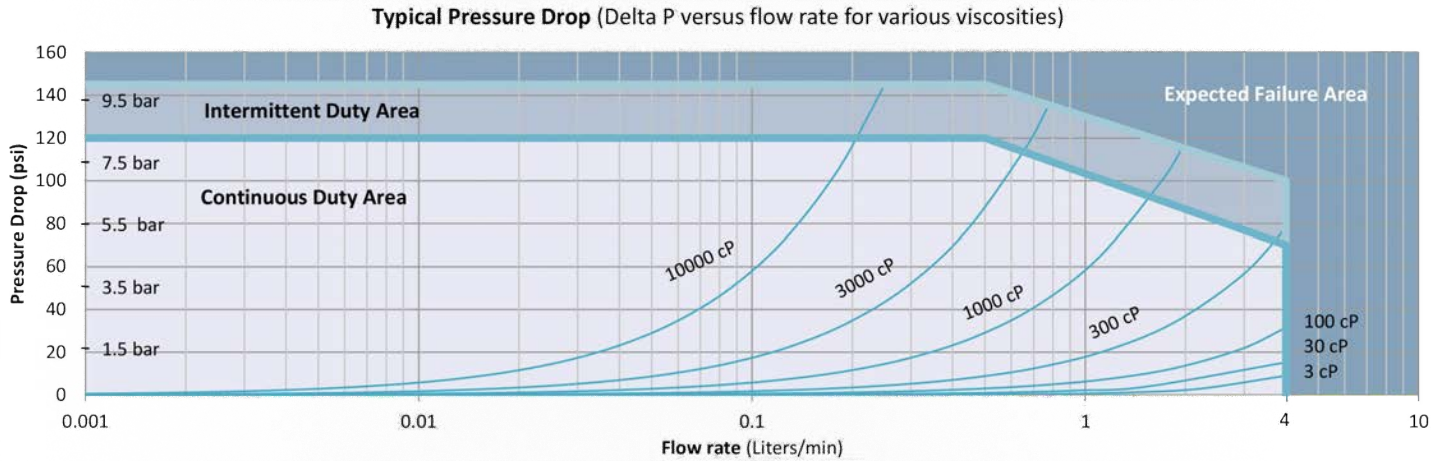

G015 / G015HZ Pressure Drop Graph

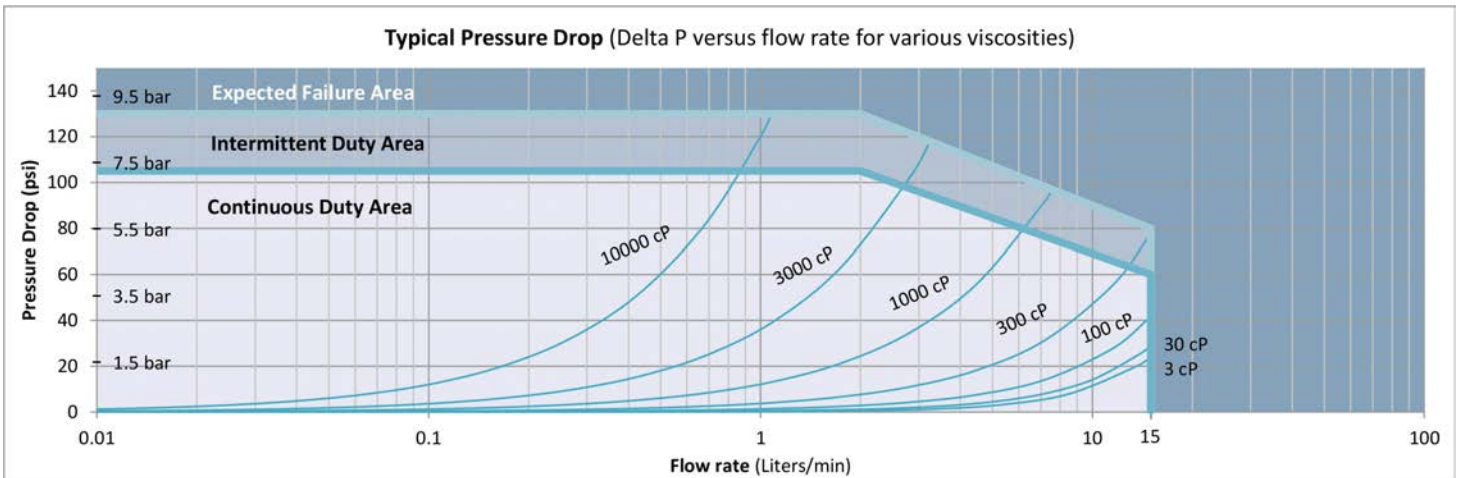

G045 / G045HZ Pressure Drop Graph

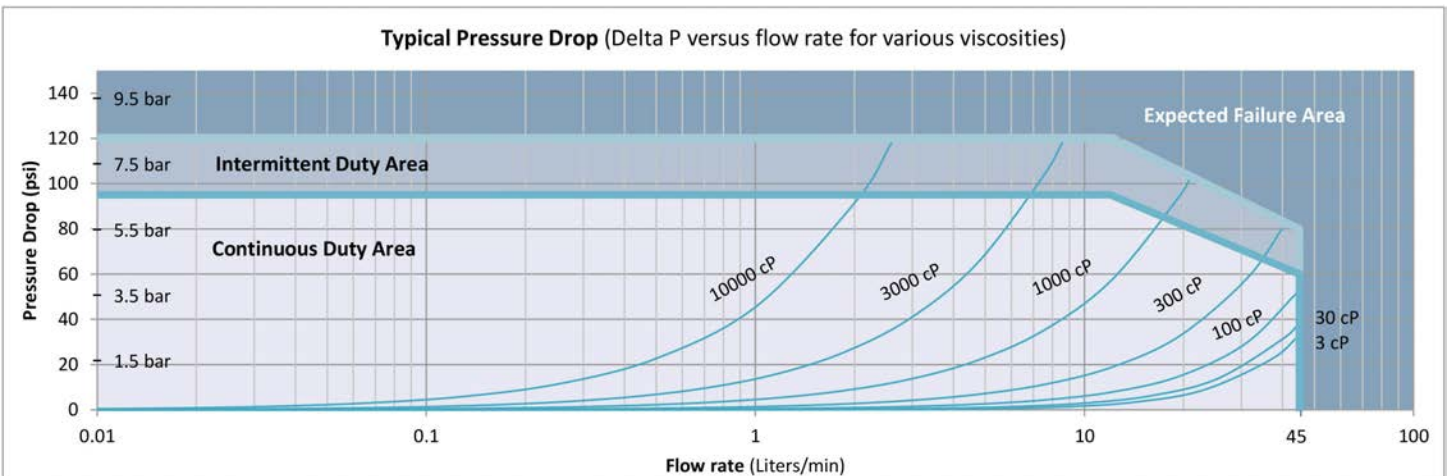

Charts

G105 Pressure Drop Graph

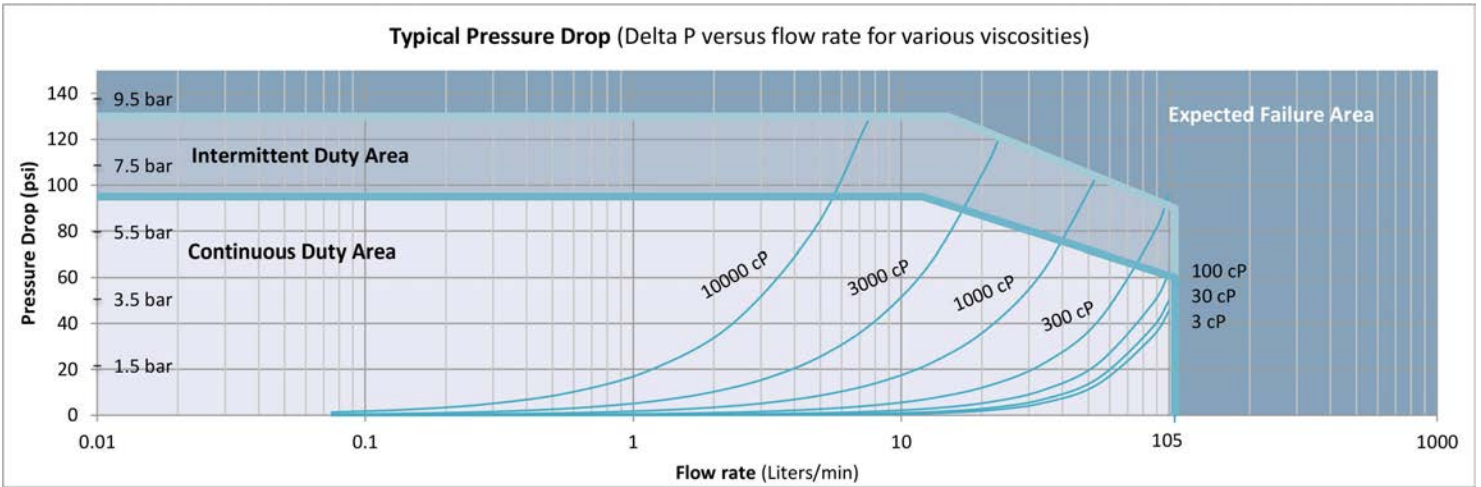

G240 Pressure Drop Graph

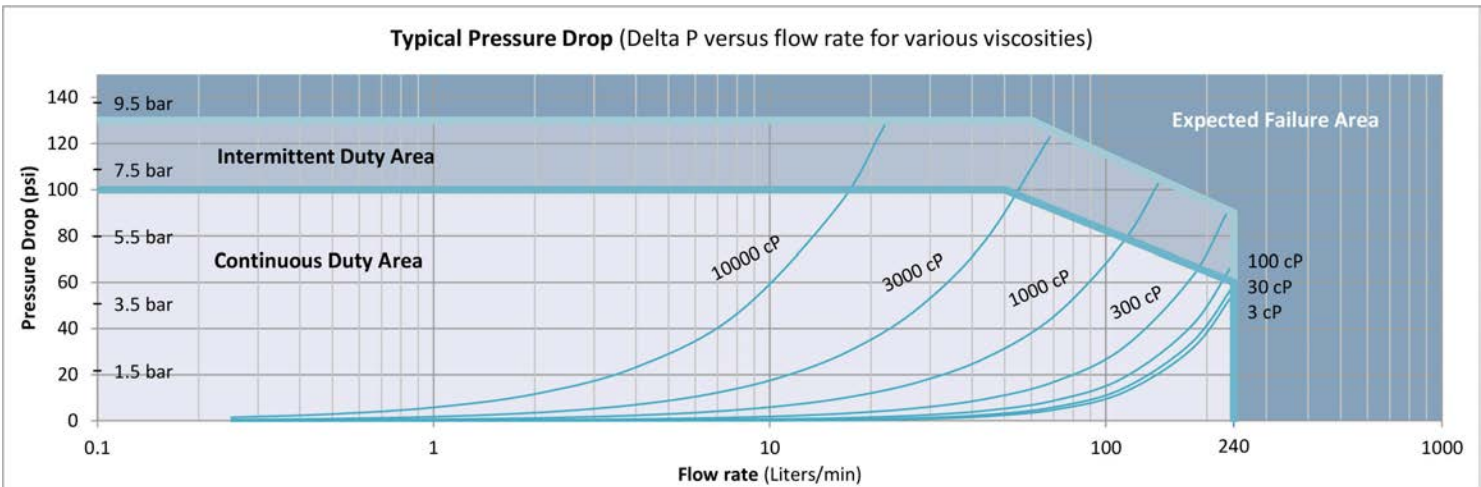



Max Machinery, Inc.
an ISO 9001:2015 certified company

Positive Displacement Flow Meters Gear Type, G-Series

Flow Meter Selections Transmitter Selections
Model # HS / / 1 - Non-Standard Options

Max Flow Range

4 Liters/Min	G004
15 Liters/Min	G015
45 Liters/Min	G045
105 Liters/Min	G105
240 Liters/Min	G240

Note: G105 & G240 not available in Manifold Mount version

Pressure

6000 psi (414 bar) HS

Note: G240 limited to 4000 psi (275 bar) if specified with NPT connections

Fluid Connection

NPT	1
SAE	2
Manifold Mount	4

Seal Selection

Viton® - FKM	1
Teflon® - PTFE***	3
Perfluoroelastomer - FFKM	5

Options

None NA

(Note: Not available in Manifold Mount) Heat Trace Option HT

* See temp chart in product manual.

** Receiver portion of 2 part transmitters are not rated Ex-Proof, consult factory.

*** Teflon® not used above 90°C for this high pressure rated product.

† Not available for hazardous location use. (Exceeds 130°C temp. limit.)

Product includes single directional calibration, bi-directional calibrations for analog and quadrature devices are optional.

Transmitter Selections

1 - Non-Standard Options

Bi-Directional Cal: BID

1 Transmitter Type

Output Type

A	A	4-20mA Output - Powered by 24 Vdc
A	B	4-20mA Output - Powered by 12 Vdc
A	C	0-10 Volt Output - Powered by 24 Vdc
A	D	0-10 Volt Output - Powered by 12 Vdc
P	N	5V Pulse/Freq. - Powered by 5-26 Vdc
Q	N	5V Quadrature - Powered by 5-26 Vdc
P	S	Current Sinking, Single Phase

Temperature Rating

- 90°C Industrial / 75°C Haz-Loc
- 155°C Ind. / 130°C Haz-Loc, 2 Part **
- 225°C Industrial, 2 Part †

Electrical Connection

- Industrial, Turck® Connector
- Hazardous Location, 1/2 Inch Conduit*

Signal Type

P	Pulse
A	Analog
Q	Quadrature



Model G015

Max Machinery, Inc.
33A Healdsburg Avenue
Healdsburg, CA 95448

maxmachinery.com
T +1 707.433.2662

©2008-2023





Max Machinery, Inc.
an ISO 9001:2015 certified company

Positive Displacement Flow Meters Gear Type, G-Series, 316 Stainless Steel

Flow Meter Selections Transmitter Selections

Model # HZ NA / 2 / 1 - Non-Standard Options

<p>Max Flow Range</p> <p>4 Liters/Min G004</p> <p>15 Liters/Min G015</p> <p>45 Liters/Min G045</p>	<p>Pressure</p> <p>6000 psi (414 bar) HZ</p>	<p>Fluid Connection</p> <p>NPT 1</p> <p>Manifold Mount 4</p>	<p>Seal Selection</p> <p>Viton® - FKM 1</p> <p>Teflon® - PTFE*** 3</p> <p>Perfluoroelastomer - FFKM 5</p>	<p>Options</p> <p>None NA</p>	<p>1 Transmitter Type</p>	<p>Output Type</p> <p>A 4-20mA Output - Powered by 24 Vdc</p> <p>A 4-20mA Output - Powered by 12 Vdc</p> <p>A 0-10 Volt Output - Powered by 24 Vdc</p> <p>A 0-10 Volt Output - Powered by 12 Vdc</p> <p>P 5V Pulse/Freq. - Powered by 5-26 Vdc</p> <p>Q 5V Quadrature - Powered by 5-26 Vdc</p> <p>P Current Sinking, Single Phase</p>	<p>Temperature Rating</p> <p>1 75°C Haz-Loc</p> <p>2 130°C Haz-Loc, 2 Part**</p>	<p>Electrical Connection</p> <p>2 Hazardous Location, 1/2 Inch Conduit*</p>	<p>Signal Type</p> <p>P Pulse</p> <p>A Analog</p> <p>Q Quadrature</p>	<p>Bi-Directional Cal: BID</p>
										<p>Bi-Directional Cal: BID</p>

* See temp chart in product manual.

** Receiver portion of 2 part transmitters are not rated Ex-Proof, consult factory.

*** Teflon® not used above 90°C for this high pressure rated product.

Product includes single directional calibration, bi-directional calibrations for analog and quadrature devices are optional.



Model G045HZ

Max Machinery, Inc.
33A Healdsburg Avenue
Healdsburg, CA 95448

maxmachinery.com
T +1 707.433.2662

©2008-2023



Available Accessories

Accessories to support your system and simplify your installation and maintenance are available direct from Max. Request yours when you order your flow meter. See the website for information and options.

Interface Software Kit

Part #	Description
SFT-KIT-001	USB drive transmitter programming software and serial cable. The following adjustments may be made to the signal output: Pulse Output Scaling, Analog Output Limits and Scaling, Signal Filtering Options and Compensation settings.



Cables

Part #	Description
181-294-060	7 meter cable - 5-pin Turck® to wire
181-294-061	15 meter cable - 5-pin Turck® to wire

Additional cable lengths available on the Max website.



Model 122 Combination Rate Indicator/Totalizers 110/220 Vac powered (frequency input)

Model	Description
122-200-000	Panel mount indicator with dual-line, 6-digit display (0.6" and 0.46"). Produces an isolated 4-20mA analog output. Provides 24 Vdc transmitter power. Can be programmed to show rate, total and/or grand total. Initial programming included as default or customer specified values.



F381 Series Filters and Filter Element Kits

Model	Description
F381 - Varies	Inline filter with 5, 10, 30 micron element options. O-rings options available to match your flow meter and system requirements.
381- Varies	Filter element replacement kit with 5, 10, 30 micron element and o-ring options to match your filter.



PCA Replacement Kits

Model	Description
Varies	PCA Replacement Kits are sold for the specific serial number located on your Max Precision Flow Meter. Contact Max technical support for ordering details and to get your quote.



Troubleshooting and Service Request

Problem	Corrective Action
No Flow through meter or high pressure drop across meter	
Solidified material blocking rotation	Heat meter to melt material. Do not exceed maximum meter operating temperature.
Debris damage or internally clogged	Refurbish meter.
Meter broken	Refurbish meter.
Fluid passes through meter, but no flow is indicated	
Transmitter cable or conduit cable incorrectly wired	Verify DC power is present at the PCA. Use a multi-meter to measure the transmitter output independent of the display or PLC.
Meter not turning	Refurbish meter.
Indicated flow does not agree with expected readings	
Air in the line	Air bubbles displace the meter just like a liquid. If you see over-reporting, purge all air from lines.
Indicator not calibrated properly	Verify K-Factor for the meter in use and compare this value to the setting used in the display.
Excessive reverse flow in system	Max transmitters' anti-dither function buffers up to 1 revolution of reverse flow. An incorrect flow total can be reported if the system reverse flow is greater than 1 meter revolution.

Additional Information Available

MMI provides refurbishment and calibration services. For more details or to submit your Service Request, go to <https://www.maxmachinery.com/services/>.

Additional information about our products, including STEP files and Sample Calibration sheets, may be found on our website at <https://www.maxmachinery.com/downloads/>.

MMI products are covered under our standard manufacturer's warranty. Details may be found at <https://www.maxmachinery.com/warranty/>.